

DELUXE STITCHER

C O M P A N Y I N C .

Head Serial Number : _____

Date Purchased : _____

Where Installed: _____

(make/model of machine)

DB45 Stitcher Head

OPERATION AND MAINTENANCE MANUAL

Wire Sizes: 25-28 Ga. Round
Crown Sizes: 7/16" (10 mm)
Capacity: 2 sheets to 1/8" (3 mm)

Before using this Stitcher Head, all operators must study this manual and follow the safety warnings and instructions. Keep these instructions with the Stitcher Head for future reference. If you have any questions, contact your local DeLuxe Stitcher Representative or Distributor.

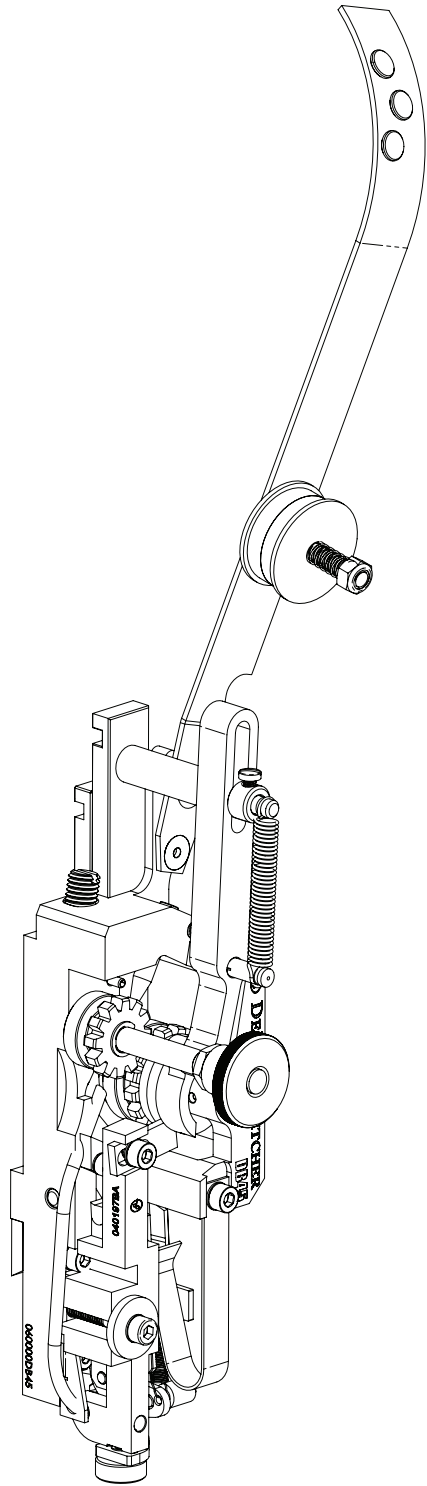

*Thank you for choosing the
DB45 STITCHER HEAD
for your binding needs*

WARNING!

DB45 Stitcher Head

Machine operators and others in the work area should always wear safety glasses to prevent serious eye injury from fasteners and flying debris when loading, operating, or unloading the stitcher machine.

Do not operate this stitcher head without all stitcher machine guards in place. Do not modify the guards in any way. Always disconnect the power supply before removing any guards for servicing.

Never operate the machine with wire feeding through the head unless there is stock above the clinchers, otherwise serious damage may result.

Always turn power off when making adjustments. Always disconnect the power cord before any disassembly work.

Table of Contents

Introduction	4
Specifications	5
Installation	6
Pre-Inspection	6
Inspection	6
Mounting	7
Assembly	7
Operation	9
Wire Threading	9
Wire Straightening	10
Adjustments and Settings	11
Maintenance	15
Lubrication	15
Cleaning	16
How to Order Spare Parts	17
Replacing Spare Parts	17
Troubleshooting	25
Appendices	27
Exploded Drawings	29
Part Number/Description Cross Reference	43
Registration Card	46
Wear/Replacement Parts	47
Warranty	48

Introduction

The DB45 Stitcher Head is the latest additions to the Company's product line and the third in a series of DB-Replacement Heads. These heads along with a complete line of fully interchangeable replacement parts are now available for current Muller-Martini* users. Anywhere the HK45 or HK55 are utilized the DeLuxe Stitcher DB45HD can be used.

The DB45HD has a stitching capacity from 2 sheets up to 3mm (.125"), a crown size of 11mm (7/16") and a minimum center to center distance measuring 45mm (1.75").

Each DB45 head weighs 4.2 lbs (1.9 kgs.) independently. The packaged shipping weight including the Wire Guide Spring, Clincher Plate Assembly and User manuals is 7.0 lbs. (3.2 kgs.).

Always use a high quality Galvanized Wire so the plating does not peel. Excessive peeling will cause clogging and the premature wear of many components.

Specifications

Weight

Shipping Weight 8.0 lbs (3.7 kg)
 Stitcher Head 4.2 lbs (1.9 kg)

Physical Dimensions

Height 9-7/8" (25 cm)
 Width 2-3/16" (55 mm)
 Depth 4-5/16" (10 cm)

Stitching Capacity Two Sheets to 1/8" (3 mm)*

Wire Types 25 through 28 round

* Actual stitching thickness capacity depends on the type of stock being stitched and the capacity of the trimmer being used.

Stitcher Head / Stitcher Machine Compatibility					
Stitcher Machine	Compatible Stitcher Heads				
JGV	DB75HD	DB75VHD	DB45HD	Loop not recommended.	⊘
Fox, 221, 235	DB75HD	DB75VHD	DB45HD	DB75VHD-LOOP	⊘
331, 335	DB75HD	DB75VHD	DB45HD	DB75VHD-LOOP	⊘
Bravo/Prima (Built before 2004)	DB75HD	DB75VHD	DB45HD	DB75VHD-LOOP	⊘
Bravo/Prima (Built 2004 or later)	DB75LPHD	DB75VLPHD	DB45LPHD	DB75VLPHD-LOOP	⊘
Valore/Presto (All)	DB75MPHD	DB75VMPHD	DB45MPHD	DB75VMPHD-LOOP	⊘
1509/Minuteman (Built before 2004)	DB75MMHD	DB75VMMHD	DB45MMHD	DB75VMMHD-LOOP	⊘
1509/Minuteman (Built 2004 or later)	DB75MMMMPHD	DB75VMMMMPHD	DB45MMMMPHD	DB75VMMMMPHD-LOOP	⊘
301/Optima/ Tempo/Supra	⊘	⊘	⊘	⊘	DB75VSHD

Installation

Pre-Inspection

Carefully inspect the condition of the shipping container before unpacking your DB45 Stitcher Head. If the container is broken or damaged and there is evidence that the stitcher head may be damaged, immediately notify the carrier who delivered the head and the DeLuxe Stitcher Graphic Arts Representative from whom the Head was purchased.

Inspection (Figure 1)

As you carefully unpack the replacement head, check to make sure all components were delivered and are in good working order. Use **Figure 1** in this manual for reference to the following pieces:

- Replacement Head for Muller Martini Stitchers: DB45
- Wire Guide Spring Assembly (040286)
- Clincher Plate Assembly (047016)
- 2.0, 2.5, 3.0 Hex Key Wrenches (G20374, G20361, G20360) and a 4.0 T-Handle Hex Key Wrench (G50708)
- Stitch samples

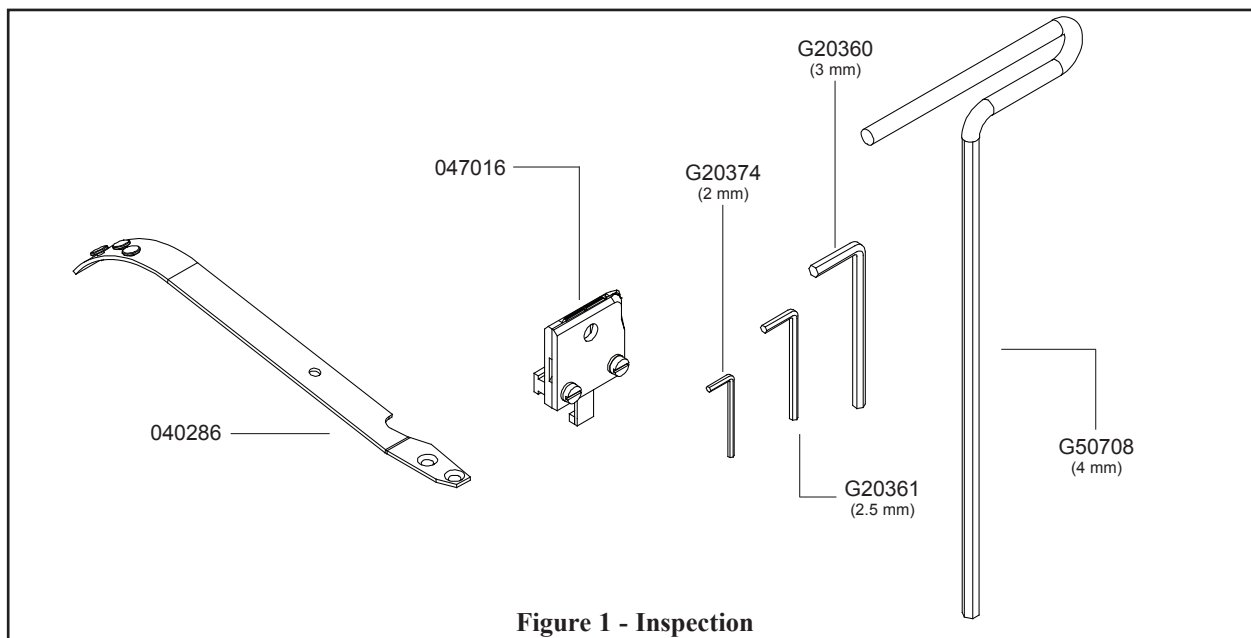
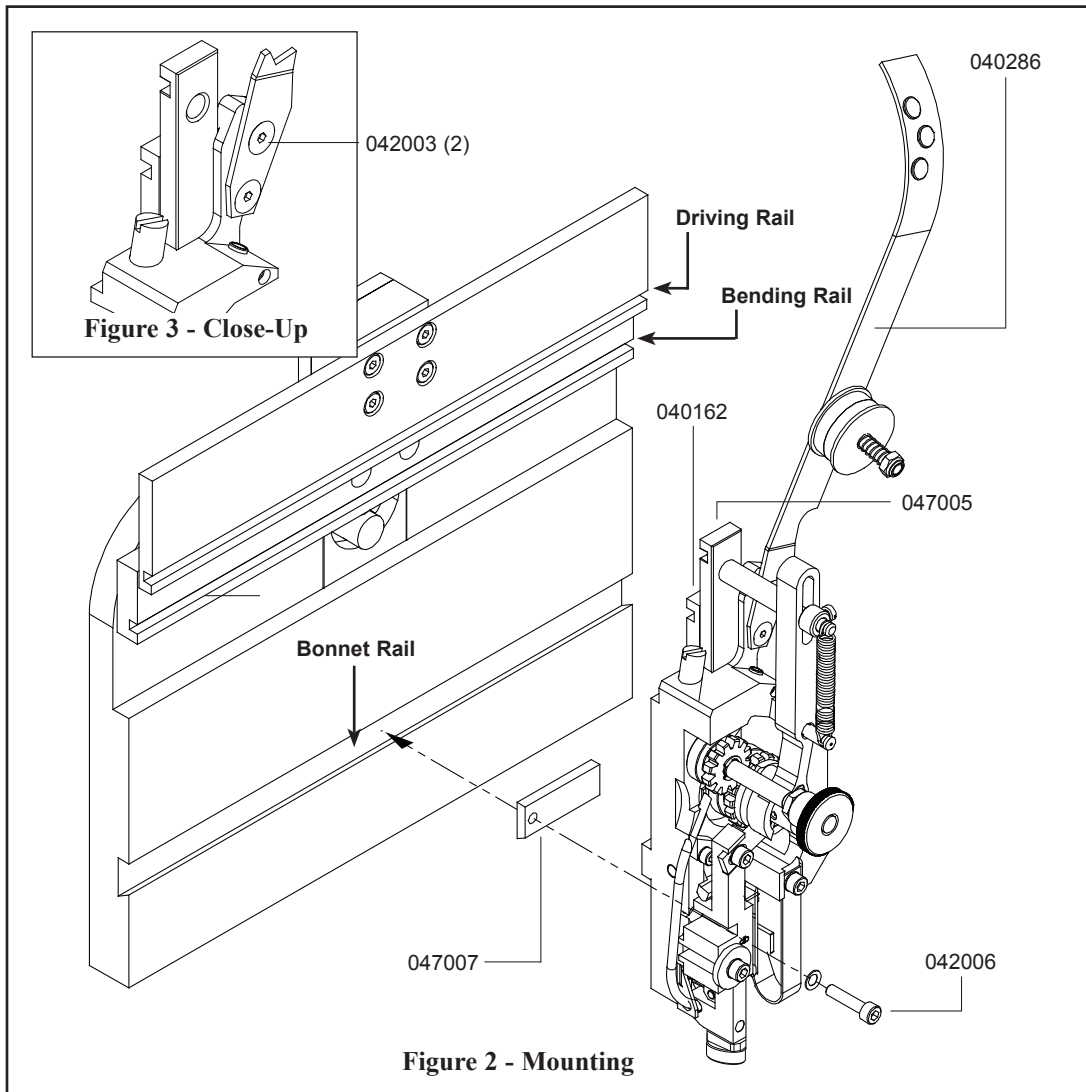

Figure 1 - Inspection

Mounting & Assembly (Figure 2)



Always disconnect the power before assembling or making adjustments to your stitcher machine.

CAUTION

Completely loosen the Head Mounting Screw (042006) which secures the Mounting Strap (047007) to the back of the DB45 Head. Use **Figure 2** for part number reference. Slide the Mounting Strap into the rail of your Müller-Martini* Stitcher Machine. Line up the groove in the Bender Slide Assembly (040162) and the groove in the Driver Slide Assembly (047005) with the grooves in the rails of the Stitcher. Slide the head downward until the key in the Bonnet slips into the groove in the Bonnet Rail just above the Mounting Strap. Secure the Head to the Mounting Strap by tightening the Screw with the supplied 4 mm T-Handle Wrench (G20373).

Remove the two (2) Flat Head Cap Screws (042003) from the DB45 Head and line the holes in the Wire Guide Spring Assembly (040286) up with the holes in the Stitcher Head. Secure the Wire Guide Spring with these same Screws.

Secure and align the Clincher Plate Assembly (047016) to the Stitcher Machine by first loosening the two (2) Cheese Head Machine Screws (072012) in the supplied Clincher Plate Assembly until the Clincher Mounting Bar (047014) is free. Slide the Mounting Bar into the rail of the Stitcher Machine and align the Clincher Slide (047002) in the corresponding rail on the Stitcher. Secure the Clincher Plate Assembly to the Mounting Bar by tightening the same two (2) Screws previously loosened. But before completely tightening the Screws, align the Clincher Points (047003), within the Clincher Plate Assembly, directly under the Driver (040152-25). Refer to **Figure 4** for part number reference.

Jog the Stitcher machine to make sure the Head has been properly mounted to the Stitcher machine. Once the Machine has been jogged through several cycles, it is safe to test the Head at full speed.

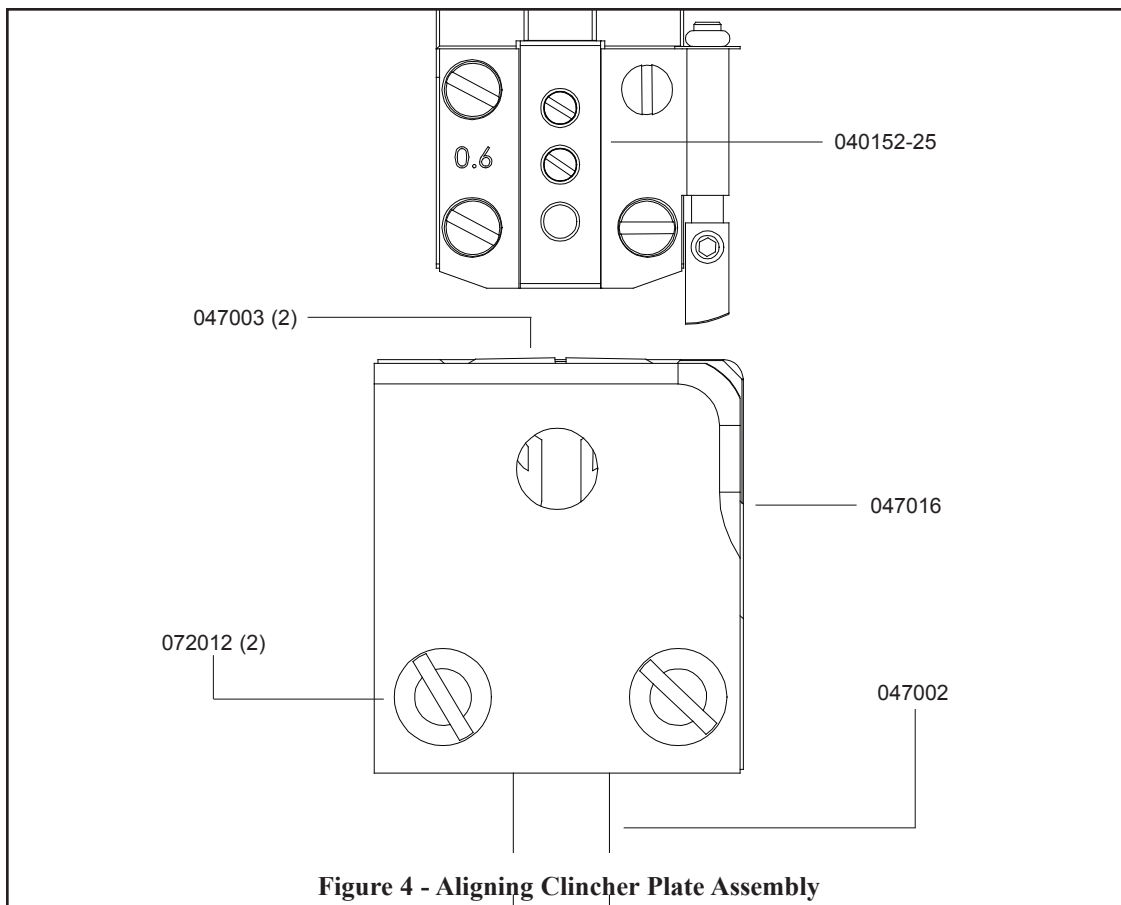

Figure 4 - Aligning Clincher Plate Assembly

Operation

Wire Threading (Figure 5)

Before the Stitcher Machine is turned on, release the Wire Holder Assembly (040543A), secured by the Wire Holder Retaining Spring (040183) by loosening the Screw (042001) on the front of the Head. Thread the wire from the Spool under the studs on the Wire Guide Spring (040286), between the Wire Oiler Felts (G20293) on the Spring and into the Wire Nozzle (070181). Turn the Feed Release Handle (040119) clockwise so that the Small Feed Gear (070112) is disengaged from the Large Feed Gear (040110A).

Continue to push wire through the DB45 Head until the end of the wire passes the Small and Large Feed Gears, enters the top of the Lower Wire Tube (040144) and begins to come out the bottom. Then, using a small screw driver, wedge the wire up until it enters the Fixed Wire Cutter (040020). Engage the Small and Large Feed Gears by turning the Feed Release Handle counter-clockwise. Jog the stitcher machine to verify that the wire has been threaded correctly.

Note: It will take two full cycles for the proper length staple to come out of the Head.

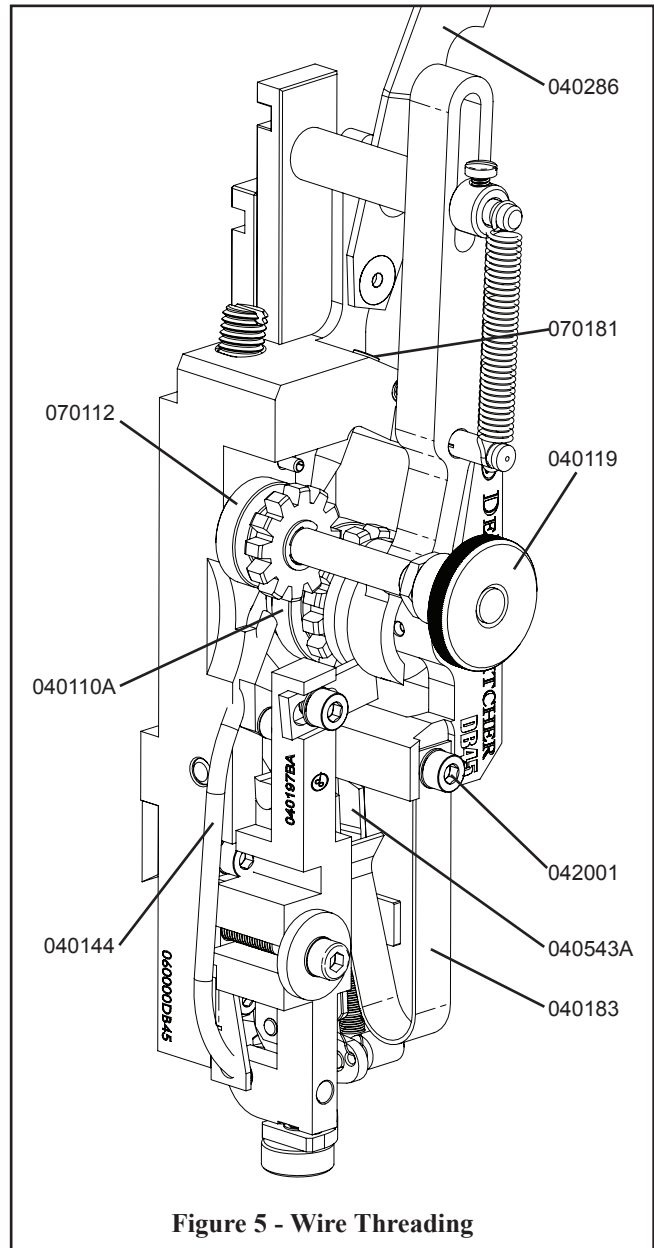

Figure 5 - Wire Threading

Wire Straightening (Figure 6)

Always disconnect the power before assembling or making adjustments to your stitcher machine.

CAUTION

For Heads Equipped with a Wire Straightener

Watch the feeding of the Wire out of the Cutter Box Assembly (040197BA) to the right of the Moving Cutter (040145B). Notice the direction the Wire is moving. For the Stitcher Head to work at its optimum capacity, the wire should be traveling in a straight horizontal direction when exiting the Head.

Top-to-Bottom Adjustment

Look to the right of the Cutter Box Assembly, as the Wire being fed through the Head. If the Wire is feeding in an upward or downward direction, the optional Wire Straightener Assembly (040206BA) will have to be adjusted by turning the knob (OSK151M-2)

If the wire is feeding in an upward direction, turn knob counterclockwise to slide Wire Straightener Assembly down to compensate. Conversely, if the wire is feeding in a downward direction, turn knob clockwise to slide Assembly up slightly. Allow enough Wire to be fed through the Head so

that an accurate assessment can be made. Make sure the ends of each cut piece of Wire are free of burrs, which would negatively affect the driving and clinching of the formed Wire.

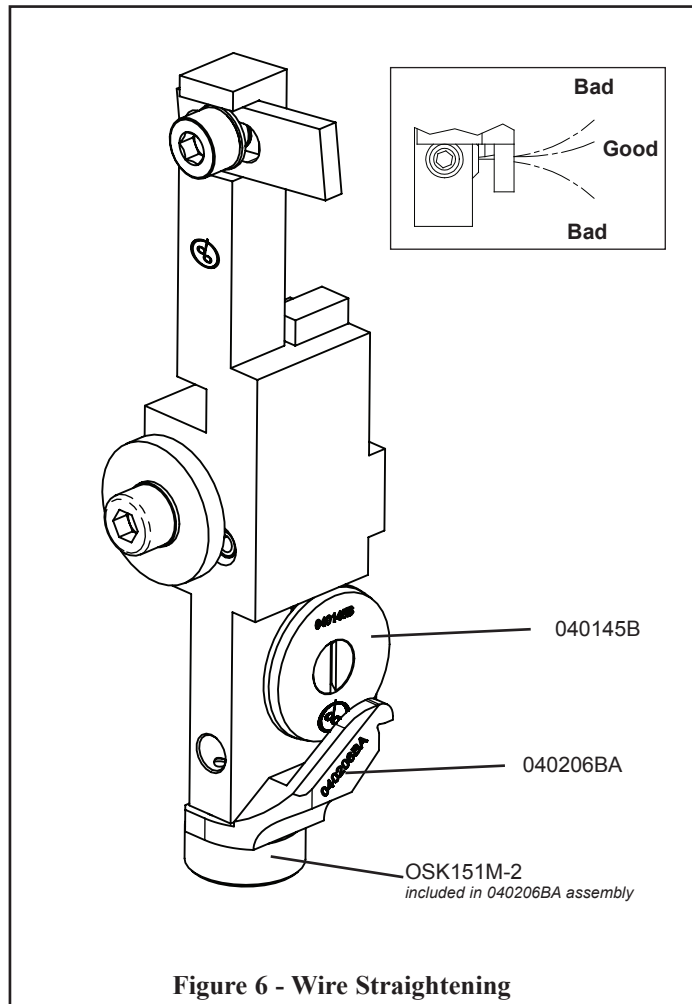

Figure 6 - Wire Straightening

If your DB45 or HK45 doesn't have a 040206BA straightener order 040197BAA KIT to upgrade your head

Adjusting the Length of the Right Leg (Figure 7)

Always disconnect the power before assembling or making adjustments to your stitcher machine.

CAUTION

Once the DB45 has been threaded and the wire engaged by the Feed Gears, it is time to begin stitching. Replace the Wire Holder Assembly (040543A) and secure it to the Head with the Wire Holder Retaining Spring (040183). Make sure to tighten the Screw (042001) at the top of the Spring afterwards.

Jog the Stitcher Machine once to load a piece of wire into the Wire Holder Assembly. Even though each DB45 Stitcher Head has been tested at the factory, the wire draw adjusted and the legs equalized, the following are directions to make these adjustments if necessary.

Lengthening the Stitch's Right Leg

If after a few stitches, the length of the stitch's right leg is too short or too long compared to that of the left, you will need to make adjustments. It is difficult to adjust the length of the left leg alone, so adjustments are always made to the right leg first. To compensate for the length of the left leg, adjust the stitch's right leg to match the left and then make adjustments for the overall length of the stitch or wire draw.

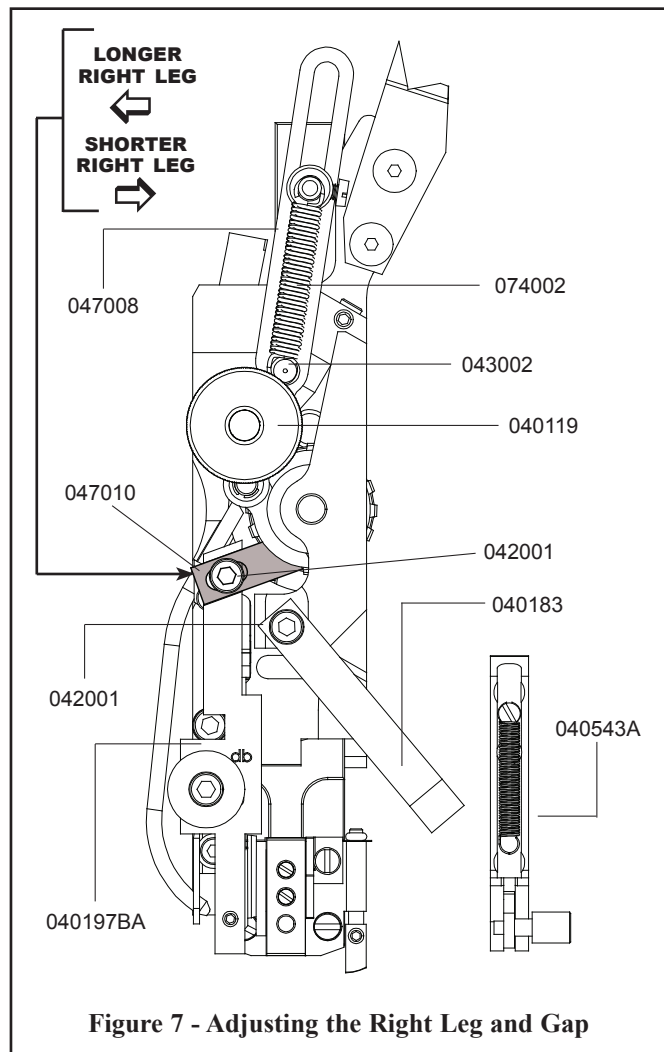

Power off the Stitcher Machine and release the Extension Spring (074002) from the Feed Gear Operating Lever Pin (043002) on the Replacement Head. Disengage the Small Feed Gear and the Large Feed Gear by turning the Feed Release Handle (040119) clockwise. Push the Feed Gear Operating Lever (047008) down which will move the pin on the Feed Gear Pinion Assembly out of the way of the Feed Gear Stop (047010). Loosen, but do

not remove, the Screw (042001) securing the Feed Gear Stop (047010) to the top of the Cutter Box Assembly (040197BA). If the right leg of the stitch is too short, slide the Feed Gear Stop to the left slightly. Tighten the Screw (042001) at this point. Replace the Extension Spring and power on the Stitcher Machine. Re-engage the Small and Large Feed Gears and jog the Stitcher to observe the length of the stitch's right leg after the initial adjustment. Continue to make adjustments and re-test the Head until the length of the stitch's right leg is satisfactory.

Shortening the Stitch's Right Leg

If the right leg of the stitch is too long, power off the Stitcher machine. Release the Extension Spring (074002) from the Feed Gear Operating Lever Pin (043002). Disengage the Small Feed Gear and the Large Feed Gear by turning the Feed Release Handle (040119). Push the Feed Gear Operating Lever (047008) down which will move the pin on the Feed Gear Pinion Assembly out of the way of the Feed Gear Stop (047010). Loosen, but do not remove the Screw (042001) securing the Feed Gear Stop to the Cutter Box Assembly (040197BA) and slide the Stop slightly to the right. Tighten the Screw at this point to secure this position. Replace the Extension Spring. Re-engage the Small and Large Feed Gears and jog the Stitcher to observe the length of the stitch's right leg after the initial adjustment. Continue to make adjustments and re-test the Head until the length of the stitch's right leg is satisfactory.



Good



Shorten Both Legs



Good



Shorten Right Leg



Lengthen Right Leg

Always disconnect the power before assembling or making adjustments to your stitcher machine.



Adjusting the Wire Draw / Stitch Gap (Figure 8)

Increasing the Overall Length of the Stitch (Decreasing the Gap)

To change the overall length of the stitch, or more specifically to change the gap between the legs of the stitch, the position of the Cutter Box Assembly (040197BA) must be adjusted. To increase the overall wire draw or decrease the gap between the legs, first power off the Stitcher Machine and release the Extension Spring (074002) from the Feed Gear Operating Lever Pin (043002) and loosen

the Screw (042002) securing the Cutter Box to the Stitcher Head. Slide the Cutter Box to the left and tighten the Screw in this position. Attach the Extension Spring and power on the Stitcher Machine. Trip the Stitcher to observe the overall length of the each stitch after the initial adjustment. Continue to make adjustments and re-test the Head until the overall length of Wire drawn is satisfactory. After the overall wire length is correct, the length of the right leg may have to be adjusted. (See previous section.)

Decreasing the Overall Wire Length



Good



Increase Gap
Move Cutter Box Right



Decrease Gap
Move Cutter Box Left

(Increasing the Gap)

To decrease the overall length of the stitch's legs or increase the size of the gap first power off the Stitcher Machine. Release the Extension Spring (074002) from the Feed Gear Operating Lever Pin (043002). (See Figure 7). Disengage the Small Feed Gear and the Large Feed Gear by turning the Feed Release Handle (040119). Push the Feed Gear Operating Lever (047008) down which will move the pin on the Feed Gear Pinion Assembly out of the way of the Feed Gear Stop (047010). Loosen, but do not remove, the Screw (042002) securing the Cutter Box Assembly (040197BA) to the Stitcher Head. Slide the Cutter Box to the right and tighten the Screw in this position. Attach the Extension Spring and power on the Stitcher Machine. Jog the Stitcher to observe the overall length of the each stitch after the initial adjustment. Continue to make adjustments and re-test the Head until the overall length of Wire drawn is satisfactory. After the overall wire length is correct, the length of the right leg may have to be adjusted. (See page 11.)

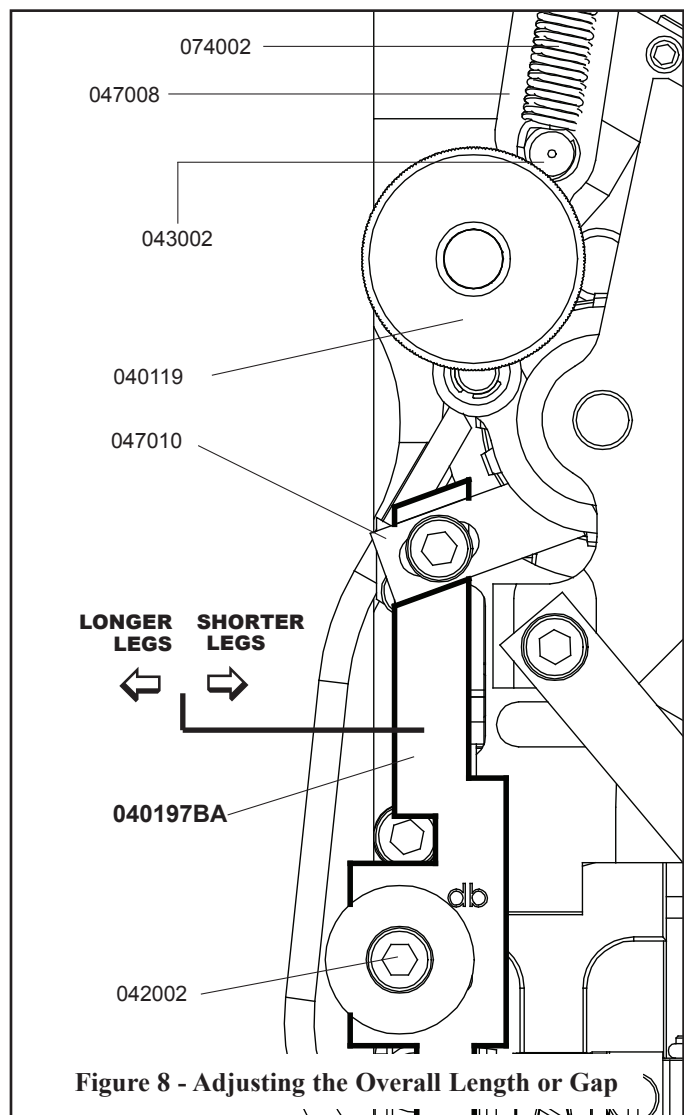
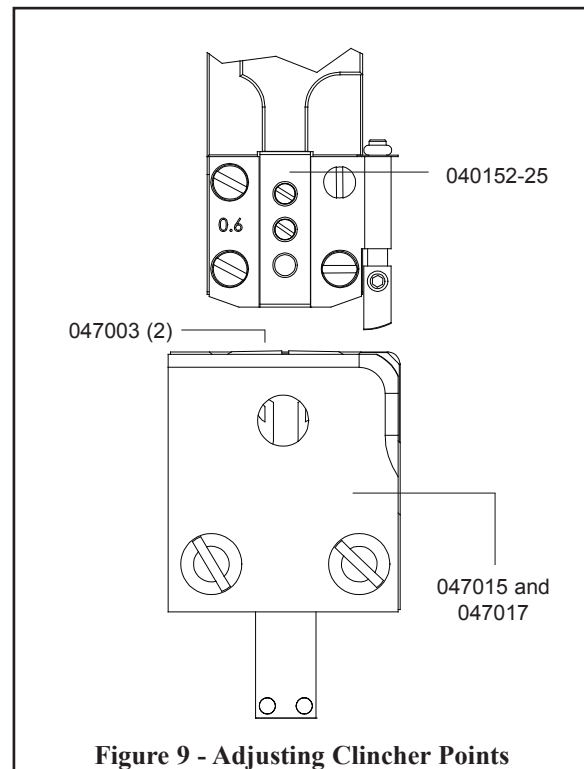

Figure 8 - Adjusting the Overall Length or Gap

Adjusting the Clincher Points (Figure 9)

If the clinch on the staple is not tight enough, the Clincher Points (047003) have to be raised. Conversely, if the clinch is too tight, the Clincher Points have to be lowered. This adjustment is made on the Stitcher Machine and so cannot be completely explained in this manual as each individual Machine is different. Refer to your saddle machine's user guide for more information.

The final position of the Clincher Points should be flush (or slightly above flush) with the Clincher Plates (047017 and 047015). The best way to see the position of the Clincher Points is to jog the Machine where the Muller Replacement Head is mounted. When the Driver (040152-25) is at the lowest position of its stroke, the Clincher Points are at their highest position. Jog the Stitcher Machine until the Stitcher Head just past this point to reveal the Clincher Points' position. To be sure that the Points are at the best position possible, run a few test stitches and compare the clinched staples.



Always disconnect the power before assembling or making adjustments to your stitcher machine.

CAUTION

Maintenance

Your DB45 Stitcher Heads have been fully lubricated at the factory, but to insure continuous superior operation and a longer life of the heads, the operator should be sure that the heads are lubricated regularly and carefully maintained. The operator should periodically inspect all moving parts for signs of wear and when required, replace the worn parts. Some parts, like the Drivers and Wire Cutters, are subject to high wear and have been designed to be reversible to provide additional surfaces. If the original driving or cutting surfaces of any of these parts show signs of wear, their position in the head can be changed, thereby providing a new surface and lengthen the life of the part. For a complete list of wear and replacement parts for your DB45 style Stitcher Heads, refer to page 43 in the back of this manual.

Lubrication (Figure 10)

Use any standard S.A.E. #10 oil for lubricating the heads. Heads that are in constant operation should be lubricated daily. Heads that are operated periodically should be lubricated every five pound wire spool change or every month, whichever comes first. Usually, only a drop of oil is required at each lubrication point. Care must be taken that those parts of the head that contact the work to be stitched are free of oil. Lubricate regularly instead of excessively. Excessive oiling will result in work becoming spotted with oil. Use one drop of oil in the following lubrication points:

- at the top of the Bonnet (040000) on either side of the Driver Slide (047005) and Bender Slide (040162).
- on the ledge of the Bender Slide Insert (077012).
- Between the Small Feed Gear (070112) and the Feed Release Cam Assembly (040118).
- in between the Wire Holder Retaining Spring (040183) and the Wire Holder Assembly (040543A).
- on the Hook Pivot Screw (042005) in the Wire Holder Assembly (040543A).
- on the Cutter Box Assembly (040197BA) behind the Cutter Operating Lever (040230).
- on each of the Clincher Point Pivot Pins (077018-2) on the Clincher Back Plate (047015)

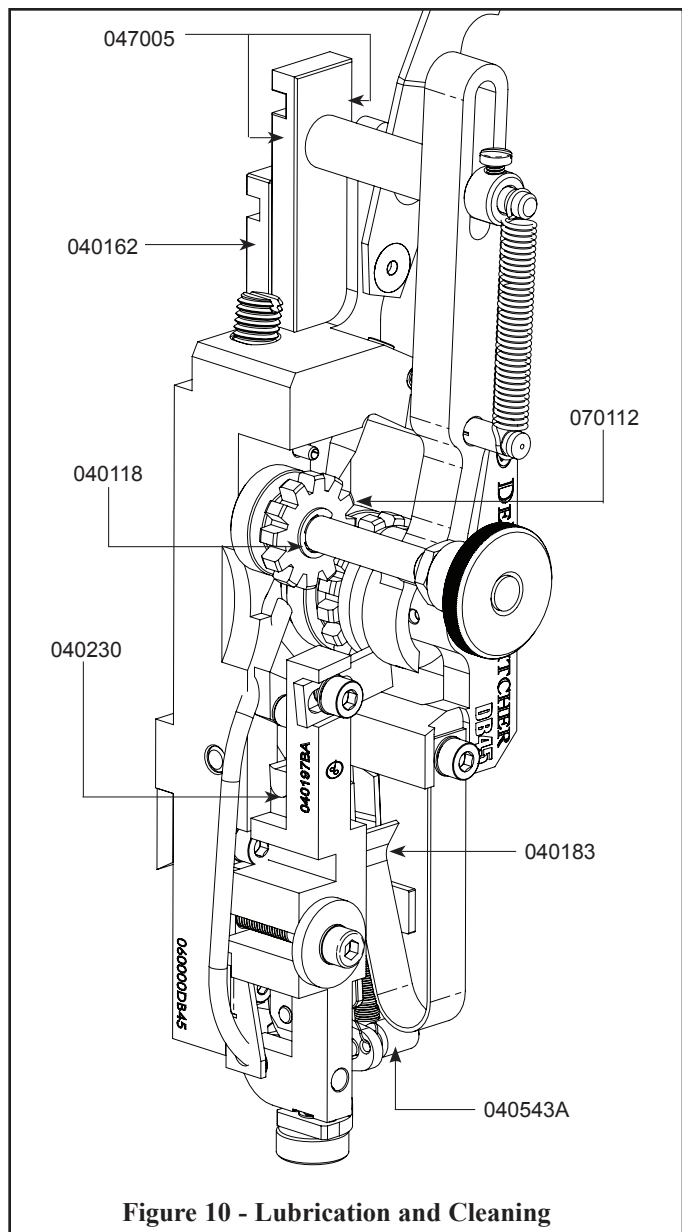

Figure 10 - Lubrication and Cleaning

Cleaning (Figure 11)

In addition to proper lubrication, routine cleaning is important for the maintenance of your DB45 Heads. The entire Head should be removed, torn down and rebuilt at least every three months and the following areas should be cleaned once every month:

- **Feed Gear Assembly:** remove the Extension Spring (074002), the Set Collar (077007) and the E-Ring (073001) to release the Feed Gear Operating Lever Assembly (047008). Slide the Driver Slide Assembly (047005) and the Bender Slide Assembly (040162) out the Back of the Bonnet and loosen the Screw securing the Friction Strip (040186). Remove the Feed Gear Assembly and wash in an oil-dissolving solvent, dry and relubricate with a light Bearing Grease; DeLuxe Stitcher recommends Shell Alvania 2.
- **Wire Holder (040543A):** release the Wire Holder from the Retaining Spring and wash in an oil-dissolving solvent, dry and return the Holder to the Head. Grease the front surface of the Wire Holder, Hook Spring and surface of Hook prior to installation.
- **Cutter Box Assembly:** loosen and remove the screw securing the Assembly to the Head,

remove

the Cutter Operating Slide (040198) and Spring (040210) and wash all three pieces in an oil-dissolving solvent. Dry the pieces thoroughly, grease the Spring and re-assemble the Cutter Box Assembly.

- **Anywhere that dust, oil or pieces of wire and paper have built up** - for example: in the Clincher Plate and around the Clincher Points.

When rebuilding DB45 Heads, be careful to lubricate high friction areas with a Multipurpose EP Grease. Refer to the exploded drawings on **pages 27 - 42** for a detailed description of the areas that need to be greased and the amount of Grease to use.

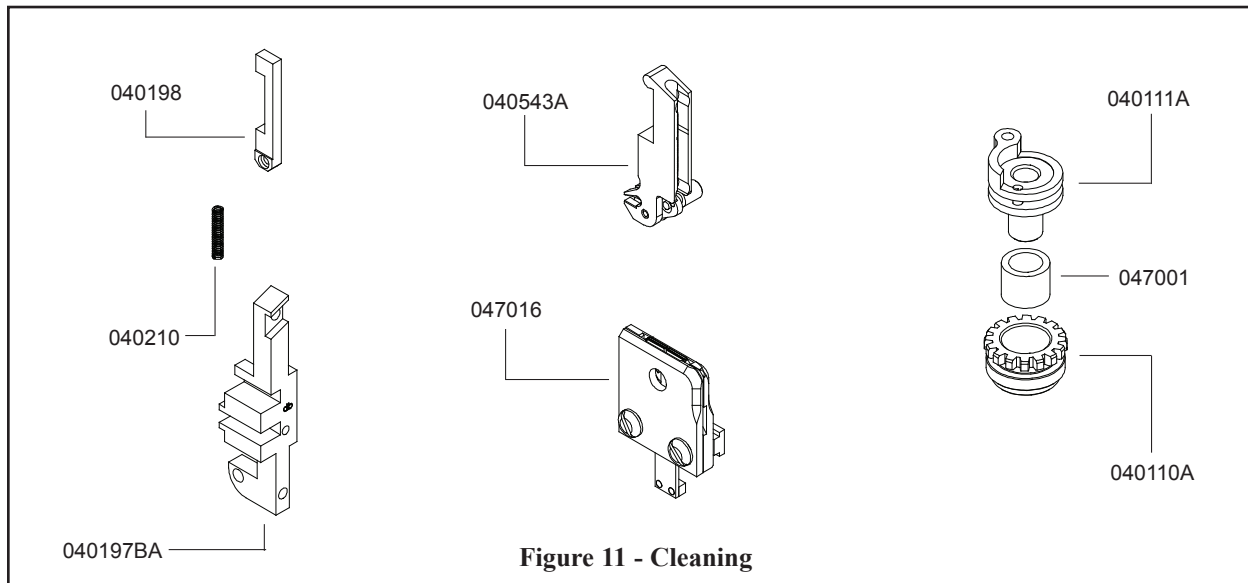

Ordering Spare Parts

In time, you will need to replace some parts in your DB45 Head. When this happens, first locate the necessary part in one of the following diagrams. Then locate the DeLuxe Stitcher part number and contact your Graphic Arts Representative to order the part by the part number, description and quantity.

Always disconnect the power cord before any maintenance is done or adjustments are made to the Müller* Replacement Head

CAUTION

Replacing Spare Parts

The following are some of the more common wear parts which will need to be removed and replaced in your DB45 Head. Most replacements require the Stitcher Head to be removed from the Stitcher Machine and disassembled. These instructions will be given first, then a more specific description for replacing the individual wear parts will follow.

General Maintenance and Repair (Figure 12)

Cut the wire feeding to the Stitcher Head just below the Wire Spool. Disengage the Small Feed Gear (070112) from the Large Feed Gear (040110A) by turning the Feed Release Handle (040119). Pull the remaining wire upward through the DB45 Head. Loosen and remove the Screw (042006) and Washer (071006) securing the Stitcher Head to the Mounting Strap (047007) and to the Stitcher Machine. Place the DB45 on a clean, flat work area and remove the Wire Guide Spring (040286) by removing the two (2) Screws (042003) secur-

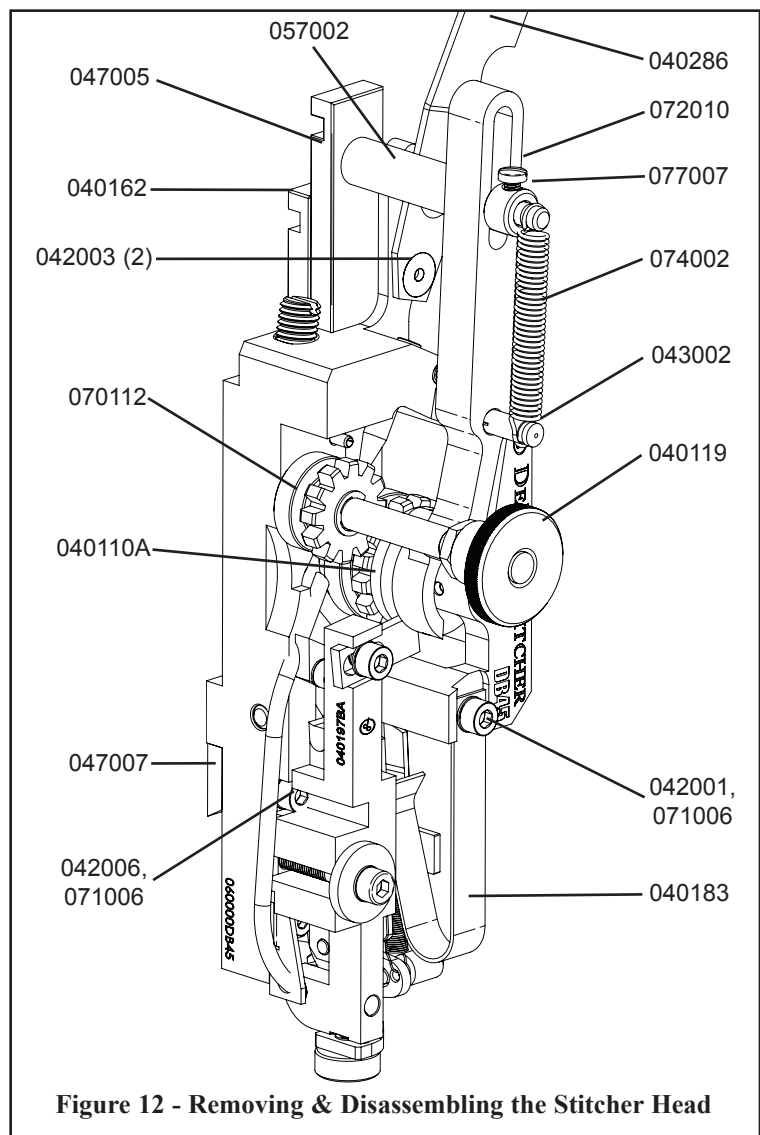

Figure 12 - Removing & Disassembling the Stitcher Head

ing the Spring to the Head. Refer to **Figures 3 and 12** for part number reference.

Loosen and remove the Screw (042001) along with the Washer (071006), securing the Wire Holder Spring (040183) to the Bonnet. Failure to do so may cause damage to the Wire Holder Spring. Refer to **Figure 12** for part number reference. Remove the Spring from the Head and the Wire Holder Assembly (040543A) from under the Spring Assembly. Disengage the Spring (074002) from the Driver Slide Shaft (057002) and from the Feed Gear Operating Lever Pin (043002). Loosen the Screw (072010) securing the Set Collar (077007) and remove it from the Driver Slide Shaft as well. Once the E-Ring (073001) is removed from the Pin (043003) in the Feed Gear Pinion Assembly (040111A), the Feed Gear Operating Lever Assembly (047008) can be removed from the Stitcher Head. Refer to **Figure 13** for part number reference.

To remove the Cutter Box Assembly (040197BA) from the DB45 Head, loosen and remove the Screw (042002), the Ribbed Washer (071006) and the Plain Washer (041001) securing the Assembly to the Head. Remove the Driver Slide Assembly (047005) and Bender Slide Assembly (040162) from the Bonnet. And then slide the Driver Slide Assembly out from the Bender Slide Assembly. Refer to **Figure 12** for part number reference.

Loosen and remove the Screw (072001) and Ribbed Lock Washer (071005) securing the Friction Strip (040186) to the Bonnet and remove the Feed Gear Assembly (040111A, 047001 and 040110A). Loosen and remove the Feed Cam Plunger Bushing (047018) and take with it the Compression Spring

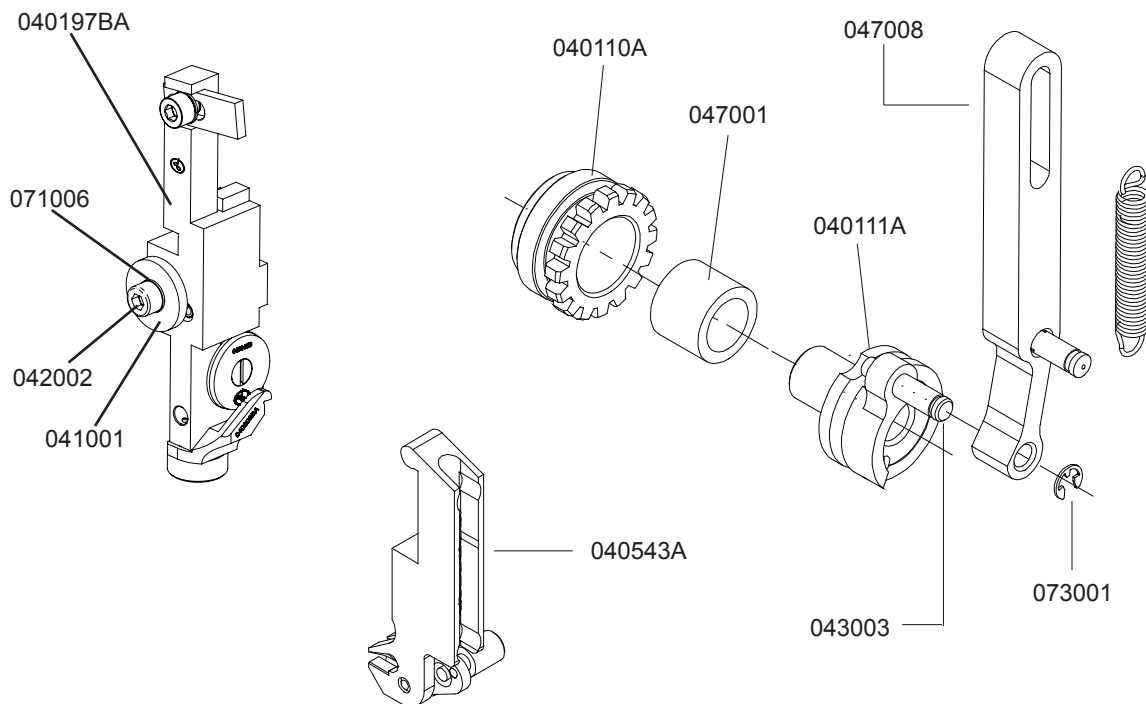
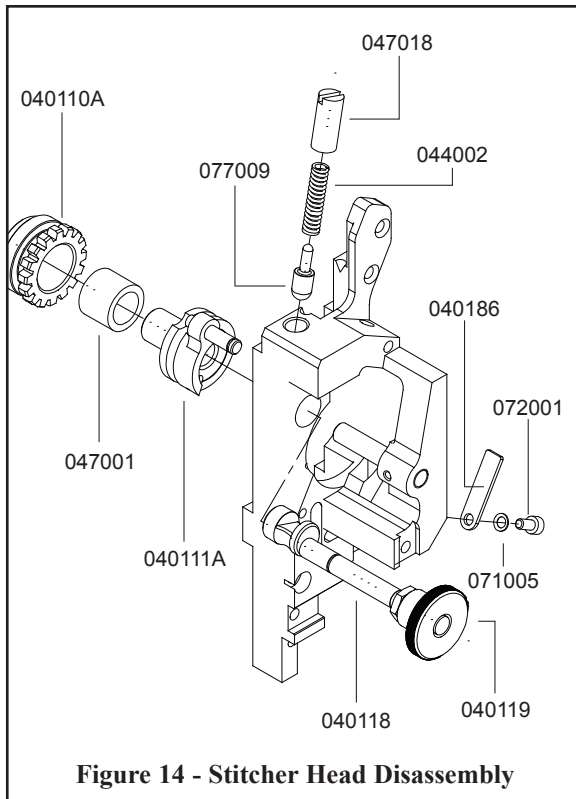

Figure 13 - Disassembling the Stitcher Head



(044002) and Feed Cam Plunger (077009) to release the Feed Release Cam Assembly (040118) and Feed Release Handle (040119). Refer to **Figure 14** for part number reference.

Removing and Replacing the Cutters (Figure 15)

If burrs appear on the ends of your cut wire or if the wire bends but does not cut, the Moving and or Fixed Cutter may need to be replaced. The position of the Moving Cutter (040145B) on the Cutter Operating Slide (040198) can be rotated several times before the part has to be exchanged for new. Simply loosen the Cutter Mounting Screw (042007) which has a **left-handed thread** and rotate the Moving Cutter until a fresh cutting edge is lined up with the Fixed Cutter (040020). Tighten the Screw at this point to secure the position.

The Fixed Cutter can also be rotated when worn by loosening the Set Screw (G20191) and rotating the position of the Cutter within the Cutter Box Assembly (040197BA). The Fixed Cutter has to be

lined up again with the Moving Cutter before the Screw can be tightened. The Screw also should be treated with a Threadlocker before tightened down on a new or rotated Fixed Cutter. Insert the Cutter Operating Slide back into the Cutter Box and make sure there is free movement between the Cutter Box and the Cutter Operating Slide when both Cutters are as close as possible to each other. If there is free movement, tighten the Screw securing the Fixed Cutter. If the Cutter Operating Slide does not slide freely within the Cutter Box, move the Fixed Cutter back into the Cutter Box slightly until free movement is re-established and then tighten the Screw at this point.

Note: Too much gap between the Cutters will cause premature wear on both parts as well as severe burrs on the ends of each piece of cut wire.

Removing and Replacing the Cutter Operating Slide (Figure 16)

Once the Cutter Box Assembly has been removed from the Stitcher Head, the Cutter Operating Slide

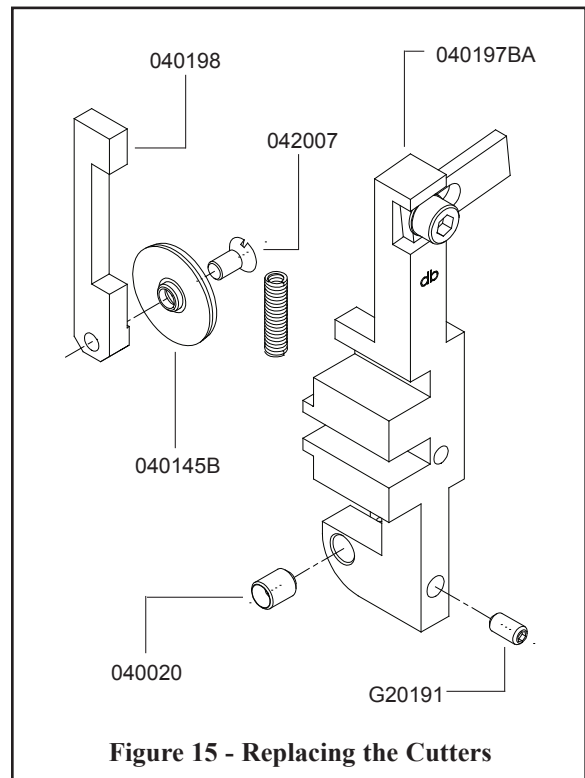

(040198) can be replaced easily. Wire that is not cut, gets an incomplete cut or has large burrs on its ends may be the result of a worn Cutter Operating Slide. Remove the Operating Slide from the Cutter Box, being careful of the Cutter Operating Spring (040210). If the Moving Cutter does not have to be replaced at this time, it will have to be removed from the Operating Slide. The Cutter Mounting Screw (042007), securing the Cutter, has a **left-handed thread** and must be loosened clockwise. Replace the worn Cutter Operating Slide and secure the existing or new Cutter to the Slide with the Screw, turning counter-clockwise. Be sure to mount the Moving Cutter securely to the Operating Slide. A loose fit adversely affects the cut and drive of the wire. Roll the Cutter Box Spring in Red E-Lube Grease and insert it in the slot of the Cutter Box. Compress the Spring with the end of the Cutter Operating Slide as you insert it back into the Cutter Box. The assembly can be secured to the Head again with the Cap Screw (042002), Ribbed Lock Washer (071006) and the plain Large Washer (041001).

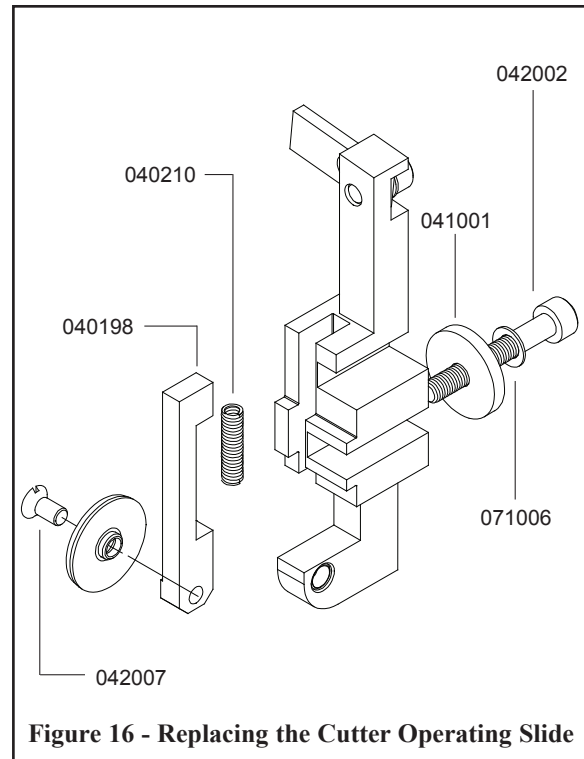

Figure 16 - Replacing the Cutter Operating Slide

Replacing the Hook Pivot Pin (Figure 17)

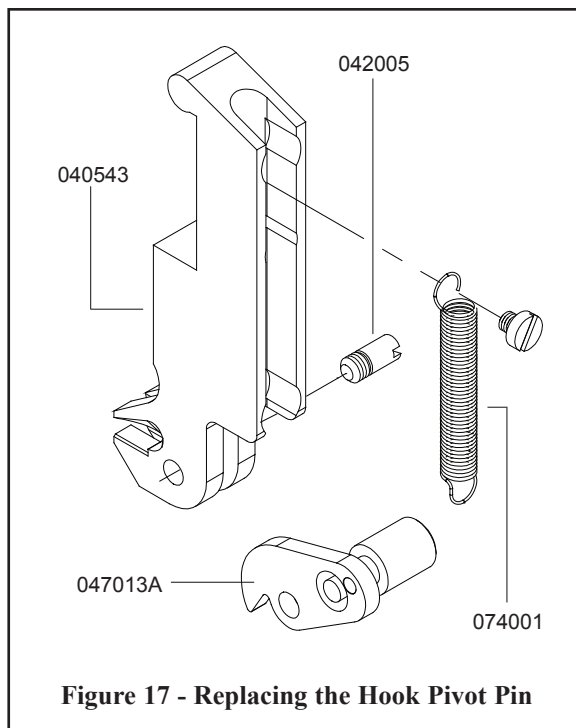

Figure 17 - Replacing the Hook Pivot Pin

The Wire Holder Hook Assembly (047013A) pivots on the Hook Pivot Pin (042005) with every stroke of the Stitcher Head. When the Pivot Pin is worn, wire may drop out of the Wire Holder Assembly (040543A) or the Hook may begin to block the entry of the wire as it is fed. Replacing the Hook Pivot Pin when worn will prevent this from happening. Release the Extension Spring (074001) from the Wire Holder Hook Assembly. Unscrew the worn Hook Pivot Pin, releasing the Hook Assembly and replace it with a new Pivot Pin. make sure the new Pin has a Nylon patch on its threads or treat it with a threadlocker. Re-attach the Extension Spring to the Wire Holder Hook Assembly and grease the outside of the Extension Spring with Red E-Lube Grease. The Wire Holder Assembly can now be replaced under the Wire Holder Spring.

Replacing the Clincher Points (Figure 18)

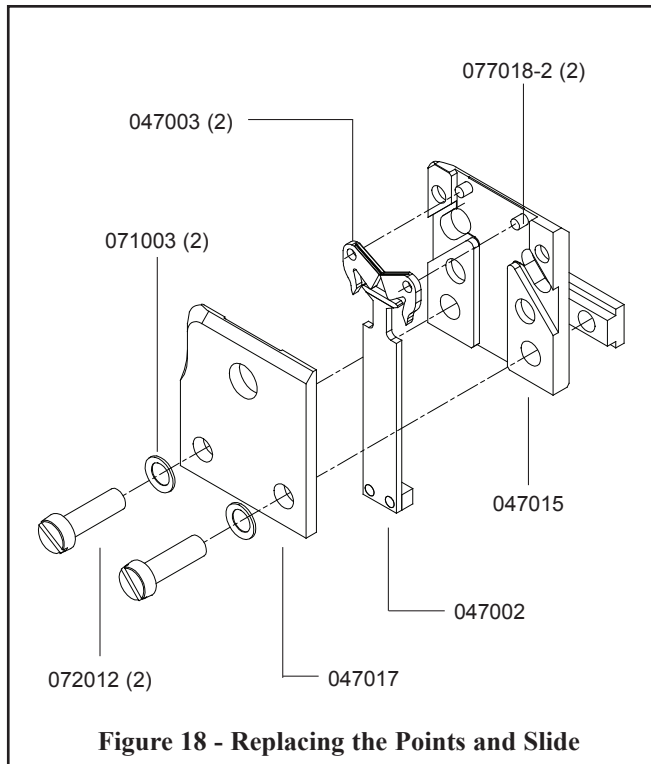

Figure 18 - Replacing the Points and Slide

If the legs of the staple are not completely clinched even though the Clincher Points (047003) are properly adjusted or if the legs of the staple “wander” from stitch to stitch, the Clincher Points or Clincher Slide Assembly may need to be replaced. Loosen and remove the two (2) Screws (072012) and Ribbed Lock Washers (071003), securing the Clincher Front Plate (047017). Release the Clincher Slide Assembly (047002) which in turn unlocks the Clincher Points. Remove the worn Points from the Clincher Point Pivots (077018-2) and replace them. Insert the existing or new Clincher Slide Assembly within the Clincher Back Plate (047015), between the two Points. Secure the Clincher Front Plate to the rest of the assembly with the two Screws.

Replacing the Driver (Figure 19)

If the rib of the Driver (040152-25) is worn or even chipped, the crown of the staples produced could be buckled or the corners may be sheared. The Driver on the DB45 Head is reverseable so that when one edge is worn or damaged, it can be reversed to extend the life of the part. Simply remove the Driver from the Driver retaining Screws (072015) and reverse its position. If both sides are worn or one of the ribs is severely broken, replace the old Driver with a new one. Secure the new Driver to the Driver Slide Assembly with the existing Screws after treating them with a threadlocker.

If the rib of the Driver (040152-25) is worn or even chipped, the crown of the staples produced could be buckled or the corners may be sheared. The Driver on the DB45 Head is reverseable so that when one edge is worn or damaged, it can be reversed to extend the life of the part. Simply remove the Driver from the Driver retaining Screws (072015) and reverse its position. If both sides are worn or one of the ribs is severely broken, replace the old Driver with a new one. Secure the new Driver to the Driver Slide Assembly with the existing Screws after treating them with a threadlocker.

Replacing the Formers (Figure 20)

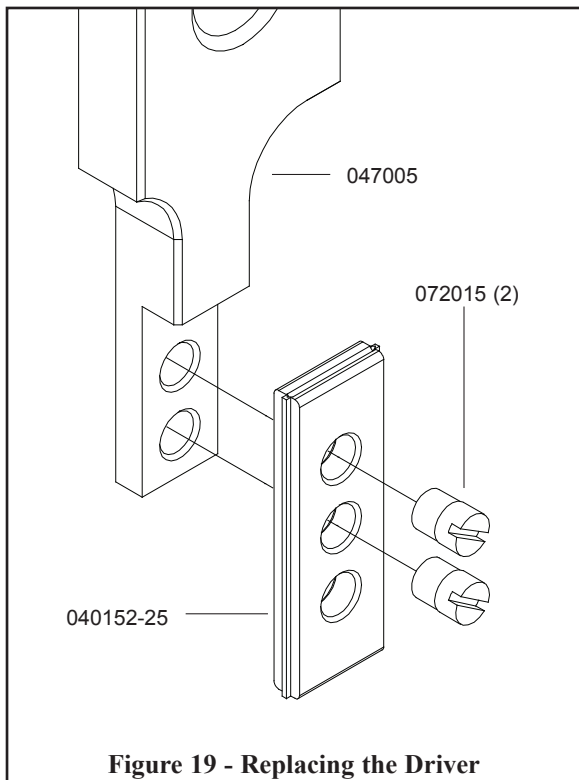
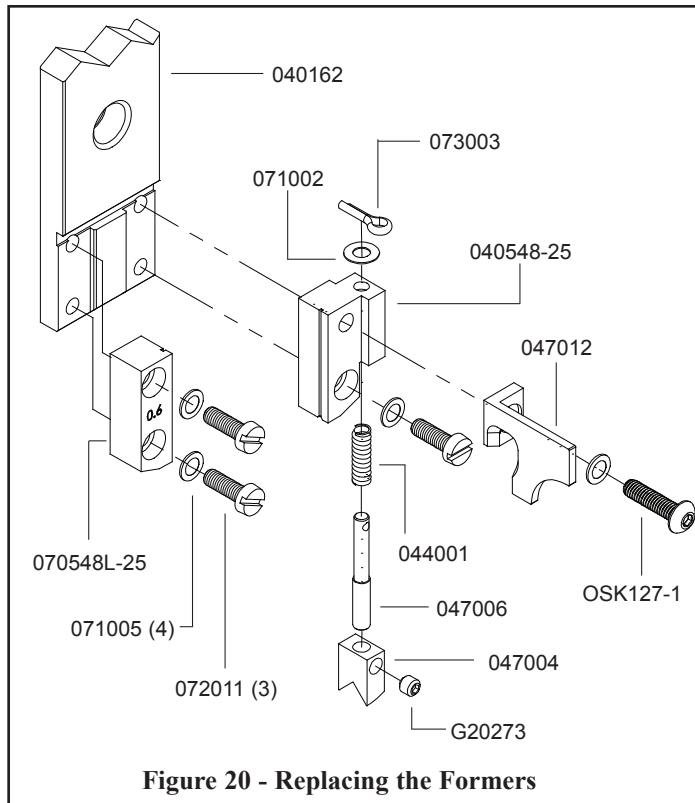

Figure 19 - Replacing the Driver

Over time, both the Right and Left-Hand Formers (040548-25 and 070548L-25) will wear with use. When this occurs the wire passing through the Formers could become distorted and not drive properly. Once the Bender Slide Assembly (040162) has been removed from the Head, replacing worn Formers is a simple task.

Loosen and remove the two (2) Screws (072011) as well as the two (2) Ribbed Lock Washers (071005) securing the Left-Hand Former to the Bender Slide Assembly. Loosen and remove the Screw (072011)



and Ribbed Washer (071005) securing the bottom half of the Right-Hand Former and the Screw (OSK127-1) securing the Hook Guide (047012) and top half of the Right-Hand Former to Bender Slide Assembly. The Centering Guide (047004), Centering Guide Post (047006), Centering Guide Spring (044001) and Shim Ring (071002) will have to be removed and transferred to the new Former before re-assembly can begin. Straighten the Cotter Pin (073003) and slip it out of the Centering Guide Post to release the Centering Guide Assembly. Insert the existing Centering Guide, the Post, and the Spring into the new Right-Hand Former. Top the Guide Post with the Shim Ring and secure the whole assembly with a new Cotter Pin. Next, exchange the old Left-Hand Former for the new one and replace it with the Screws and Washers removed previously. Make sure to treat the Screws with a threadlocker before inserting them into the

Head. Similarly, secure the new Right-Hand Former using the old Screws and Washers. Be sure to replace the Hook Guide along with the Right-Hand Former and treat the Screws with a threadlocker.

Replacing the Hook Guide (Figure 20)

When continued use wears or damages the Hook Guide (047012), it can be easily exchanged for new by removing the Screw (OSK127-1) securing it. When the Hook Guide wears or breaks, the Wire Holder Hook Assembly in the Wire Holder is not activated with each stroke of the Head. If this occurs, no wire will be allowed into the Wire Holder to be formed or driven. Be sure to use a threadlocker on the Screws when replacing the Hook Guides to the Right-Hand Formers.

Re-assembling the Stitcher Head (Figure 21)

After all cleaning and lubrication is complete and any spare parts that have been added are secure, the DB45 Head is ready to be re-assembled. Refer to the exploded drawings on **pages 27 - 42** for a detailed description of the areas that need to be greased and the amount of Grease to use.

1. Slip the Feed Gear Assembly over the Feed Gear Shaft (040114). Make sure it is pressed flush against the Bonnet (040000). The Pin (043003) on the Feed Gear Pinion Assembly (040111A) should be positioned just right of the Feed Release Handle (040119). (See **figure 21**)

2. Grease the front of the Driver Slide Assembly (040162) and slip it between the Formers on the Bender Slide Assembly (047005), after greasing the front of it. Insert both parts into the slot on the

back of the Bonnet (040000). Make sure that the Driver Slide Assembly still moves freely in between the Bender Slide Assembly.

3. Secure the position of the Large Feed Gear (040110A) with a Friction Strip (040186), held in place with Screw (072001) through a Ribbed Lock Washer (071005). Secure the Mounting Strap (047007) to the back of the Bonnet with the Mounting Screw (042006) through a Lock Washer (071006).

4. Slip the Feed Gear Operating Lever Assembly (047008) over the Pin (043003) on the Feed Gear Pinion Assembly and over the Driver Slide Shaft (057002) which has been greased. Secure the Set Collar (077007) to the Shaft with a Screw (072010) and secure the Feed Gear Operating Lever Assembly to the Feed Gear Pinion Assembly with an E-Ring (073001). There should be approximately a 0.04" (1mm) gap between the Set Collar and the Feed Gear Operating Lever.

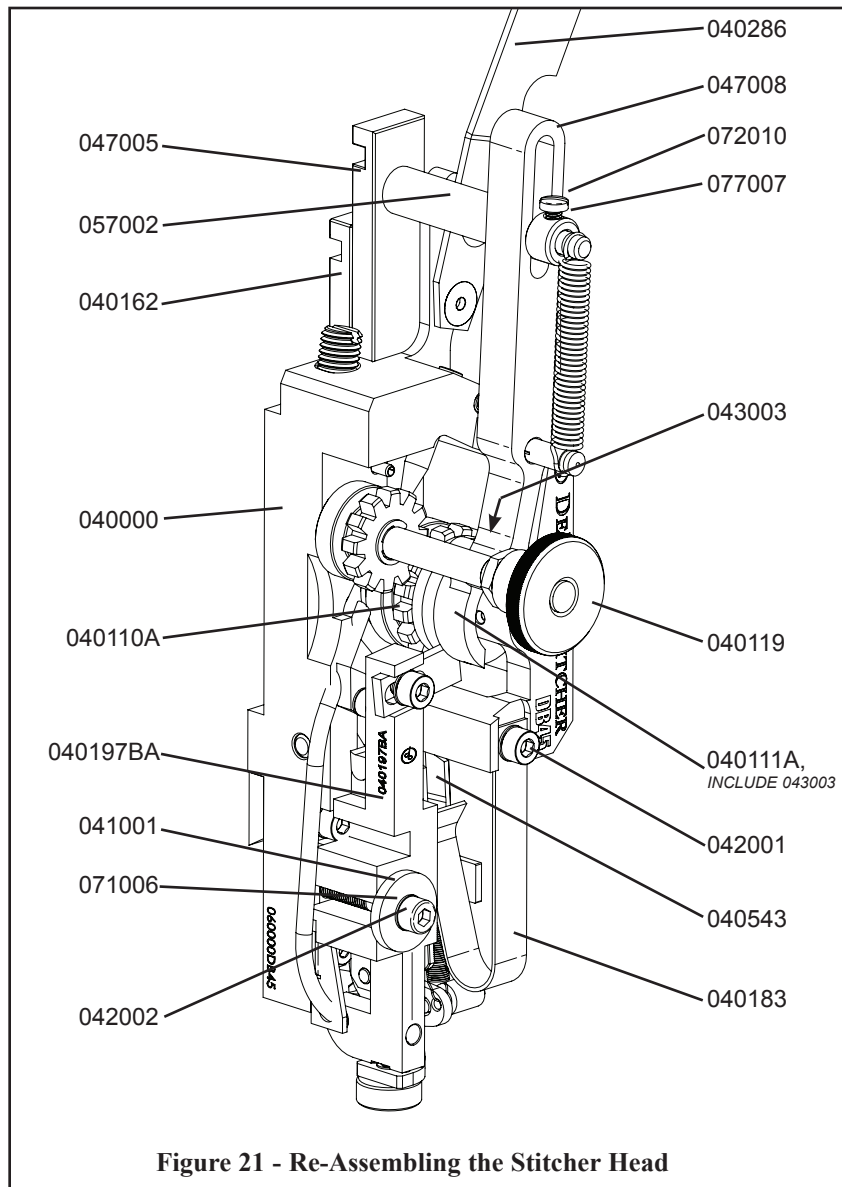

Figure 21 - Re-Assembling the Stitcher Head

5. Grease the top of the Cutter Operating Slide (040198). Secure the Cutter Box (040198) to the Bonnet (040000) with a Screw (042002) through one (1) Ribbed Lock Washer (071006) and one Washer (041001).
6. Secure the Wire Holder Assembly (040543) under the Wire Holder Retaining Spring (040183) and tighten the Screw (042001).
7. Secure the Wire Guide Spring (040286) to the Bonnet (040000) with two (2) Screws (042003).

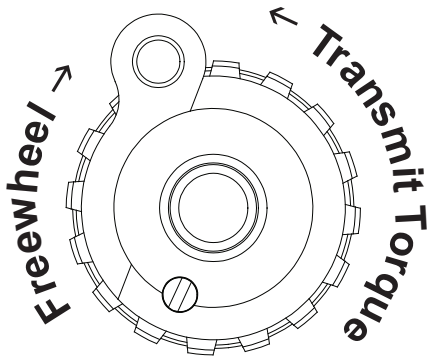

Figure 22 - Feed Gear Pinion Assy

Troubleshooting (Figure 22)

The quality and quantity of work that can be produced with the DB45 Head is dependent upon the operator making all adjustments as accurately as possible and carefully maintaining the head. The cause of staple imperfections usually can be traced to inaccurate settings or normal wear of moving parts. In the event of trouble of this nature occurring, the operator can, by referring to the following troubleshooting chart, quickly locate and remedy the cause or causes of the trouble.

The following is a brief list of problems and solutions which should cover the majority of situations encountered when stitching with the DB45 Stitching Heads.

Always disconnect the power cord before any maintenance is done or adjustments are made to the Muller Replacement Head

CAUTION





	<p>PROBLEM: Right Leg Short</p> <p>SOLUTION: Move the Feed Gear Stop to the left, slightly. (See pages 11 - 12)</p>
	<p>PROBLEM: Right leg Long</p> <p>SOLUTION: Move the Feed Gear Stop to the right and the Cutter Box to the left, slightly. (See pages 11 - 12)</p>
	<p>PROBLEM: Corner Buckled</p> <p>SOLUTION: Check the Driver for a chipped corner and rotate or replace it if needed. (See page 21) Use a heavier gauge wire.</p>
	<p>PROBLEM: Leg(s) Buckled</p> <p>SOLUTION: Check the Wire Cutters and Wire Cutter Operating Slide for wear and rotate or replace if needed. (See pages 19 - 20) Use a heavier gauge wire. Make sure the Clincher Plate is aligned with the Head.</p>

Figure 23 - Troubleshooting

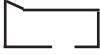

PROBLEM: Crown Buckled

SOLUTION: Check to make sure the Driver is not damaged; reverse or replace if necessary. Verify that the Formers are not worn; replace if need be. (See page 21). Use a heavier gauge wire.

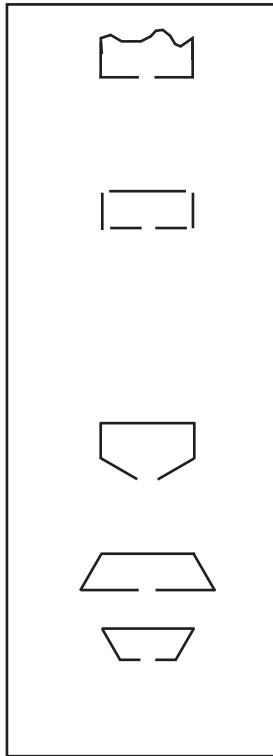
PROBLEM: Stitch in Pieces

SOLUTION: Clean and lubricate the Head (See page 15 - 16) Check for hard or brittle wire and replace. Check the tension of the Wire Holder Spring and replace Spring if too loose. Look for wear in Wire Holder pivot point in Bonnet.

PROBLEM: Loose Clinch

SOLUTION: Raise the Clincher Points. (See page 14)

PROBLEM: Legs are Spread or Contracted

SOLUTION: Check the Wire Cutters for wear and rotate or replace if needed. (See pages 19 - 20) Check the Formers for wear in the grooves and replace if needed. Use a heavier gauge wire.

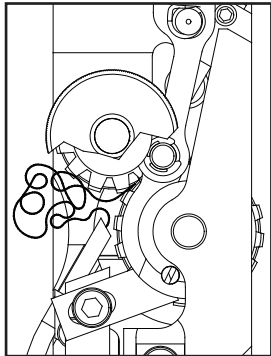

PROBLEM: Wire jam near Feed Gear

SOLUTION: Cutters may be too tight. Check for the following worn parts and replace if necessary. Fixed Cutter, Moving Cutter, Cutter Operating Slide, Cutter Operating Lever, Bender Slide Insert, Wire Guide, Hook, Hook Pivot Pin, Feed Gear Friction Strip and Wire Holder. There may be debris in the Wire Holder or the Clutch may not be working properly. Oil the Oiler Felt on the Wire Guide Spring.

Figure 23 - Troubleshooting

The DB45 Head

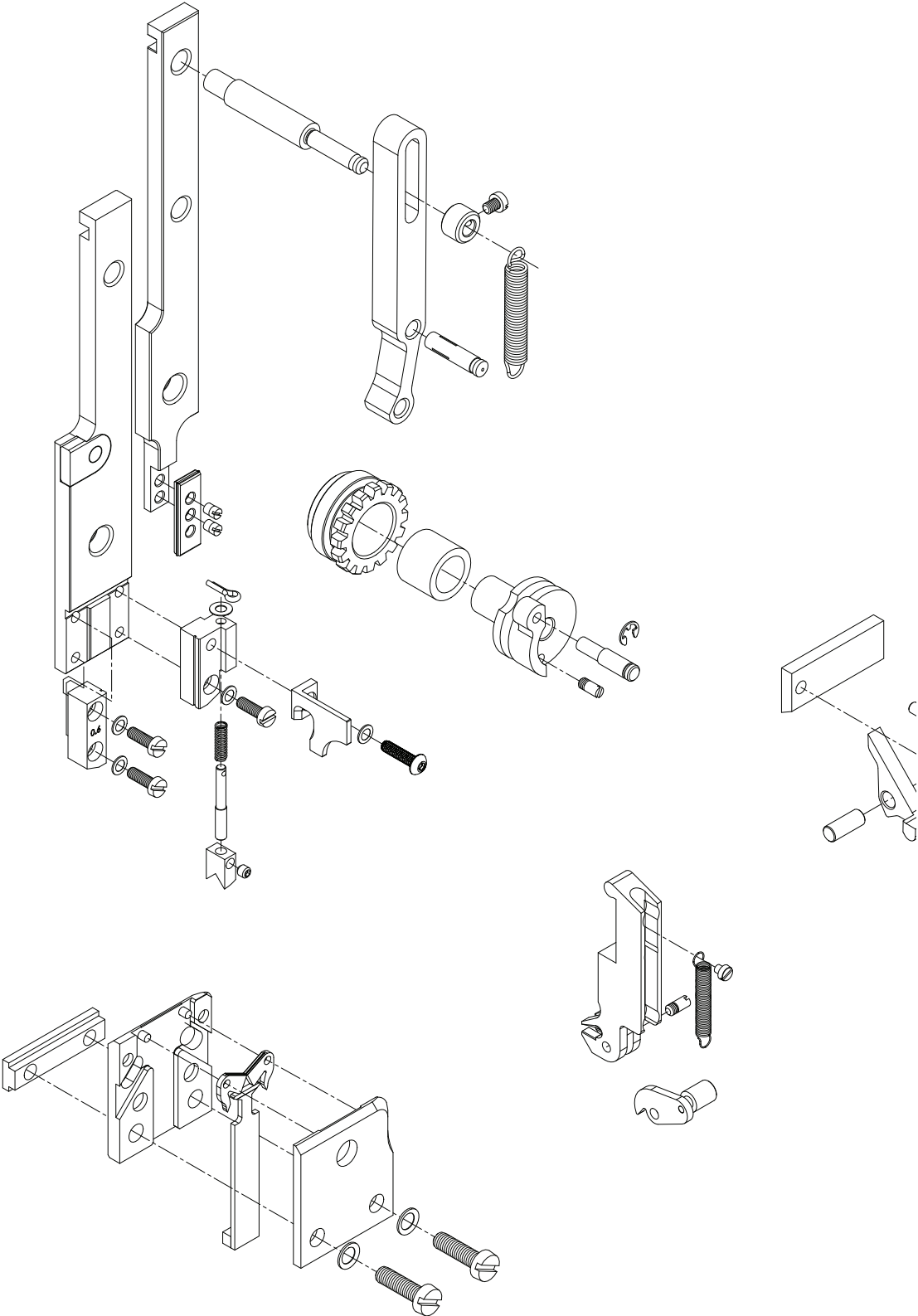

The DB45 Head

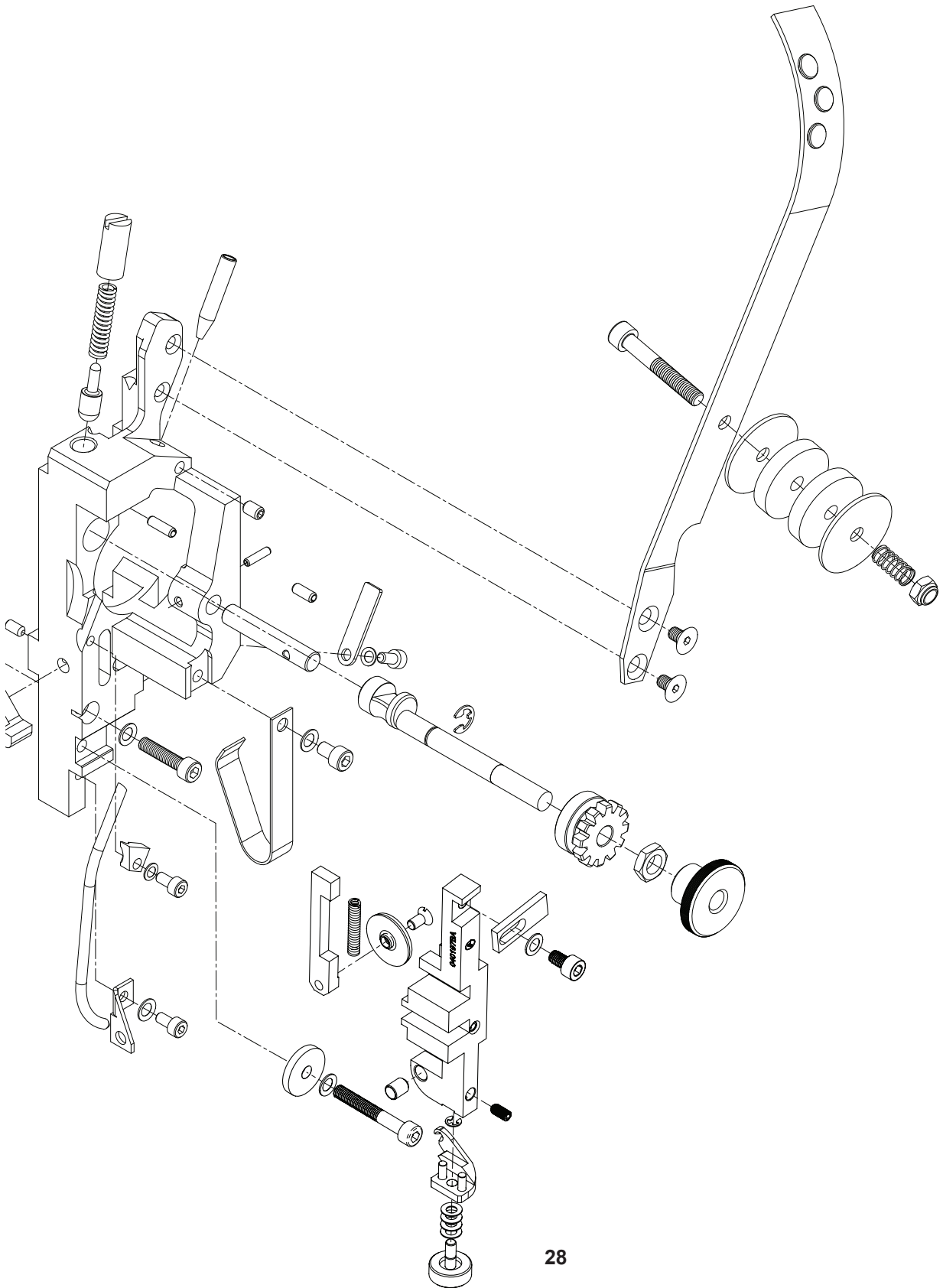

Bonnet and Wire Guide Spring Sub-Assemblies

PARTS USED FOR
MULLER MINUTEMAN
STITCHERS

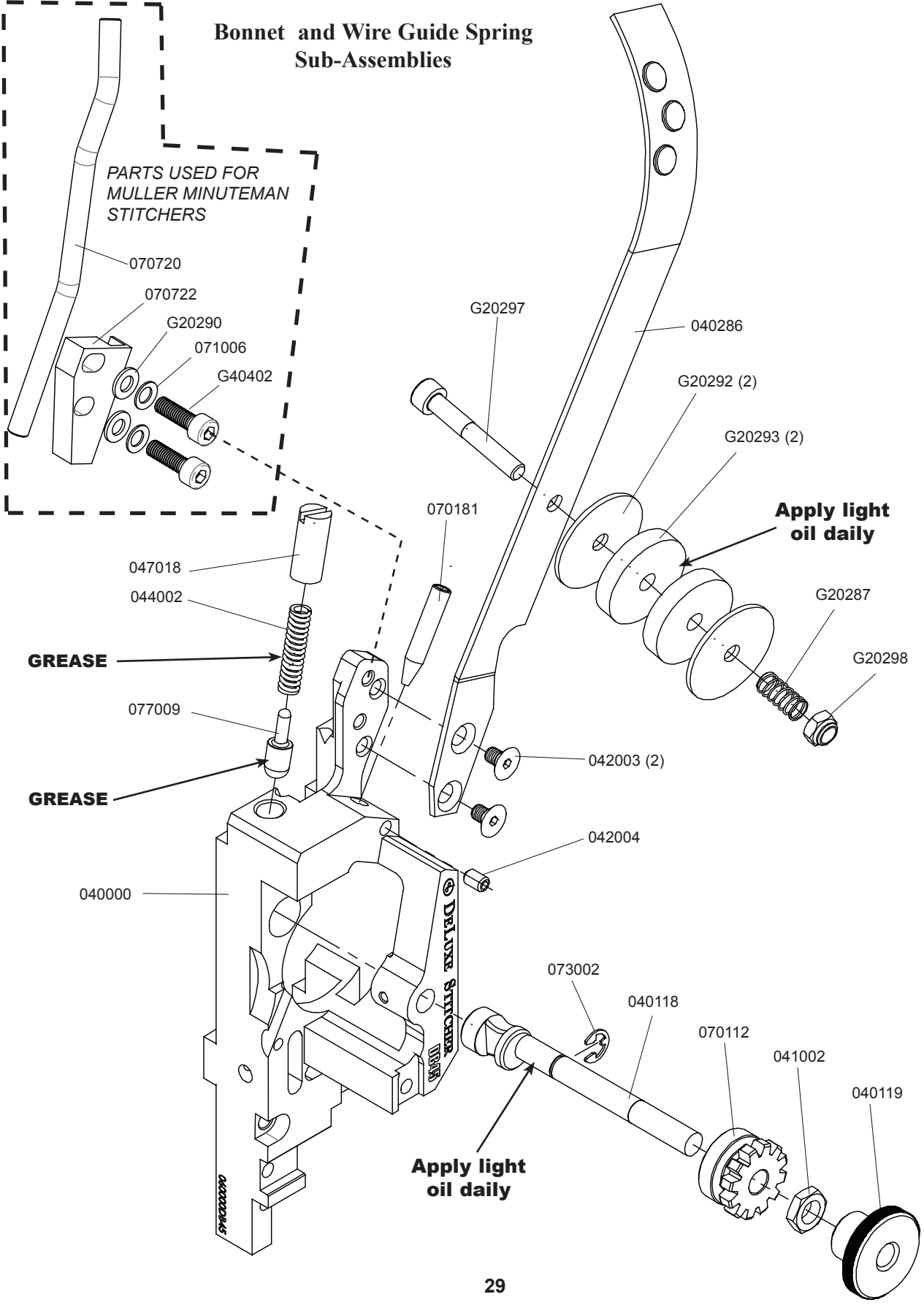

Bonnet and Wire Guide Spring Sub-Assemblies

DeLuxe PART No.	Replaces Muller No.	DESCRIPTION	QUANTITY
G20287		Wire Oiler Felt Spring	1
G20292		Wire Oil Felt Washer	2
G20293		Wire Oiler Felt	2
G20297		Screw M6x1.0x40	1
G20298		Nylock Lock Nut, M6x1	1
040000	0305.2037.1	Bonnet	1
040118	0305.2022.4	Feed Release Cam Assembly	1
040119	0031.0307	Feed Release Handle	1
040286	0305.2024.4	Wire Guide Spring Assembly	1
041002	0031.0158	Hex Head Jam Nut	1
042003	0030.1016	Screw M5x.8x8	2
042004	0030.1715	Screw M5x.8x10	1
044002	0354.1041.4	Feed Cam Compression Spring	1
047018	0881.0366.4	Feed Cam Plunger Bushing	1
070112	0881.0003.4	Small Feed Gear	1
070181	0881.0009.4	Upper Wire Tube	1
073002	0031.0759	E-Ring	1
077009	0881.0032.4	Feed Cam Plunger	1
070720	1509.1352.3	Wire Guide Tube	1
070722		Tube Clamp, DB45	1
071006	0031.5105	Lock Washer Ribbed M5	2
G20290		Flat Washer M5	2
G40402		Screw M5 x 16mm	2

Bonnet and Supporter Sub-Assemblies

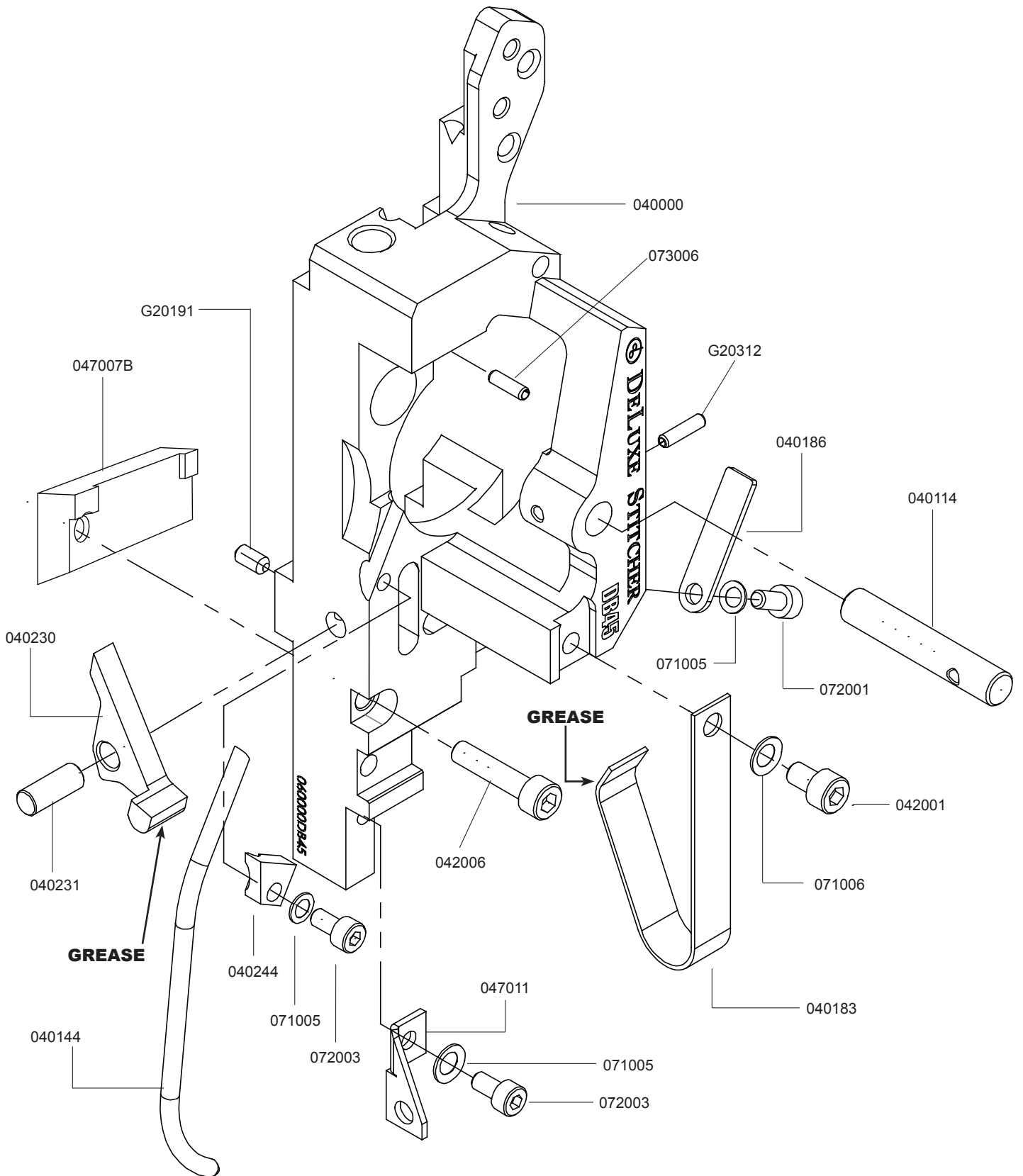

Bonnet and Supporter Sub-Assemblies

DeLuxe PART No.	Replaces Muller No.	DESCRIPTION	QUANTITY
G20191		Screw M4x.7x8	1
G20589		Screw M4x.7x10	1
040000	0305.2037.1	Bonnet	1
040114	0305.2034.4	Feed Gear Shaft	1
040144	0305.2018.4	Lower Wire Tube	1
040183	0882.0079.4	Wire Holder Spring	1
040186	0305.2052.4	Friction Strip	1
040244	0305.2004.4	Wire Tube Clamp	1
040230	0305.2028.4	Cutter Operating Lever	1
040231	0305.2027.4	Cutter Operating Lever Pivot Pin	1
042001	0030.0030	Screw M5x.8x8	1
042006	0305.2047.4	Head Mounting Screw	1
047007B	0305.2021.4	Mounting Strap	1
047011	0305.2040.4	Lower Wire Tube Holder	1
071005	0031.5104	Lock Washer Ribbed M4	3
071006	0031.5105	Lock Washer Ribbed M5	1
072001	0030.0016	Screw M4x0.7x8	1
072003		Screw M4x0.7x12	2
G20312		Spirol Pin M3x12	1
073006	0031.6312	Spring Pin M3x12	1

Driver and Bender Inserts

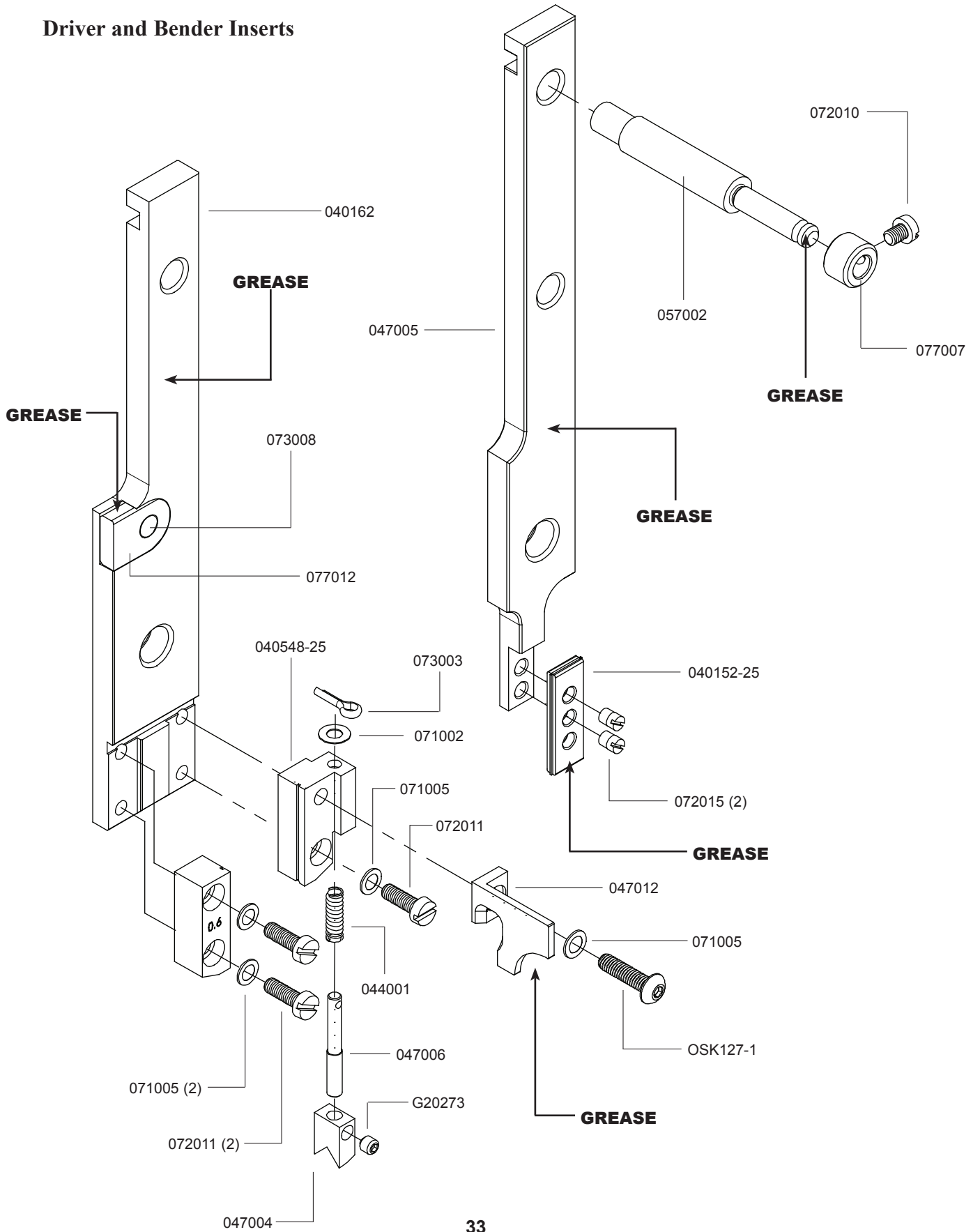

Drivers and Bender Inserts

DeLuxe PART No.	Replaces Muller No.	DESCRIPTION	QUANTITY
G20273		Screw M4x.7x4, with Nylon Patch	1
OSK127-1		Screw M4x0.7x16	1
040152-25	0305.2019.4	Driver - .6MM	1
040162	0305.2008.3	Bender Slide Assembly	1
040548-25	0305.2014.4	Former RH 25-28 Wire	1
044001	0305.2046.4	Centering Guide Spring	1
047004	0305.2006.4	Centering Guide	1
047005	0305.2009.3	Driver Slide Assembly	1
047006	0305.2016.4	Centering Guide Post	1
047012	0305.2041.4	Hook Guide	1
057002	0882.0019.4	Driver Slide Shaft	1
070548L-25	0881.0016.4	Former LH 25-28 Wire	1
071002	0023.0931	Shim Washer	1
071005	0031.5104	Lock Washer Ribbed M4	4
072010	0030.3447	Screw M4x0.7x5	1
072011	0030.3451	Screw M4x.7x12	3
072015	0249.1054.4	Driver Retaining Screw	2
073003	0031.5021	Cotter Pin	1
073008	0031.9106	Rivet	1
077007	0881.0022.4	Set Collar	1
077012	0881.0040.4	Bender Slide Insert	1

Complete Cutter Box Assembly - 040197BAA

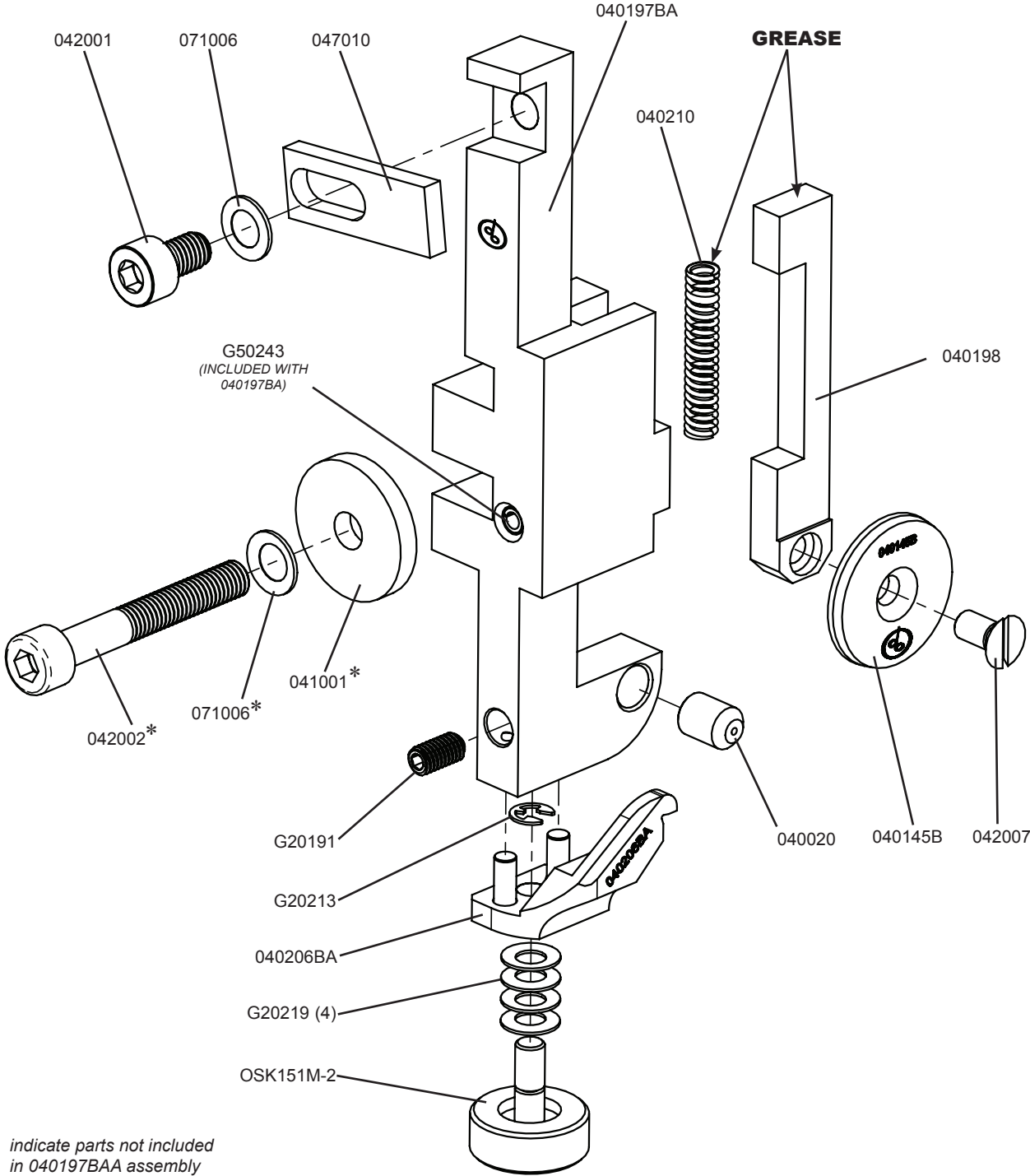

* indicate parts not included in 040197BAA assembly

Cutter Box Assembly

DeLuxe PART No.	Replaces Muller No.	DESCRIPTION	QUANTITY
G20191		Screw M4x.7x8	1
G20213		E-Ring, 1/8"	1
G20219		Disk Spring M4	4
G50243	0031.6025	Spring Pin M4 x 14	1
OSK151M-2		Wire Straightener Knob	1
040020	0882.0058.4	Fixed Cutter	1
040145B	0881.0025.4	Moving Cutter - Steel	1
040197BA	0305.2029.3	Cutter Box Assembly	1
040198	0305.2007.4	Cutter Operating Slide	1
040206BA		Wire Straightener Assembly	1
040210	0305.2045.4	Cutter Operating Spring	1
041001	0022.0042	Large Washer	1
042001	0030.0030	Screw M5x.8x8	1
042002	0030.0527	Screw M5x.8x35	1
042007	0305.2048.4	Cutter Mounting Screw	1
047010	0305.2032.4	Limit Stop	1
071006	0031.5105	Lock Washer Ribbed M5	2

Feed Gear Assembly

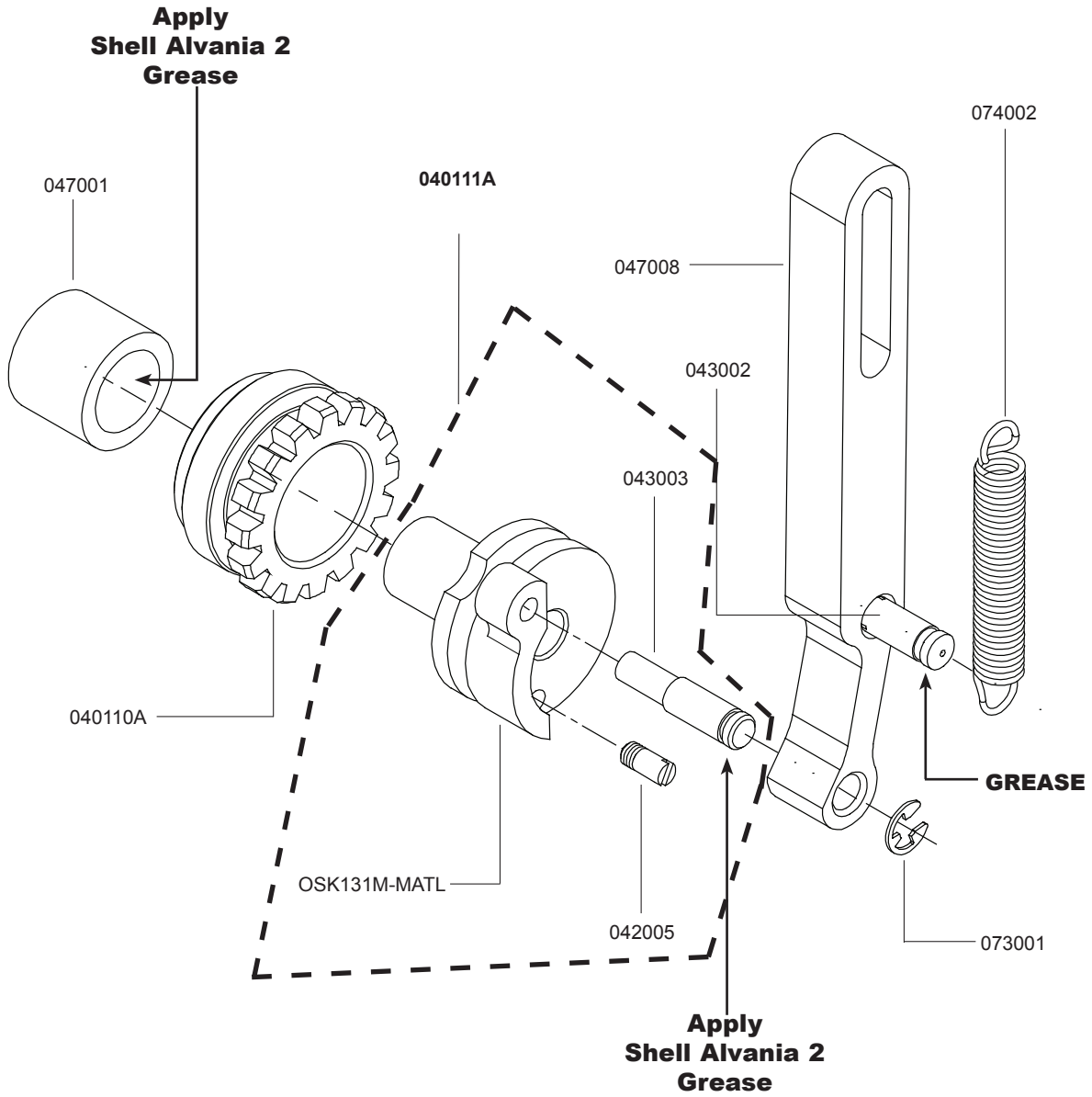

Feed Gear Assembly

DeLuxe PART No.	Replaces Muller No.	DESCRIPTION	QUANTITY
040110A	0305.2001.4	Large Feed Gear	1
040111A	0305.2031.4	Feed Gear Pinion Assembly	1
OSK131M-MATL		Feed Gear Pinion	1
042005	0305.2035.4	Hook Pivot Screw	1
043002	0031.6491	Grooved Pin	1
043003	0305.2038.4	Pin	1
047001	0039.5121	Clutch Bearing	1
047008	0305.2030.4	Feed Lever Assembly	1
073001	0031.0757	E-Ring	1
074002	0034.0302	Extension Spring	1

Wire Holder Assembly - 040543A

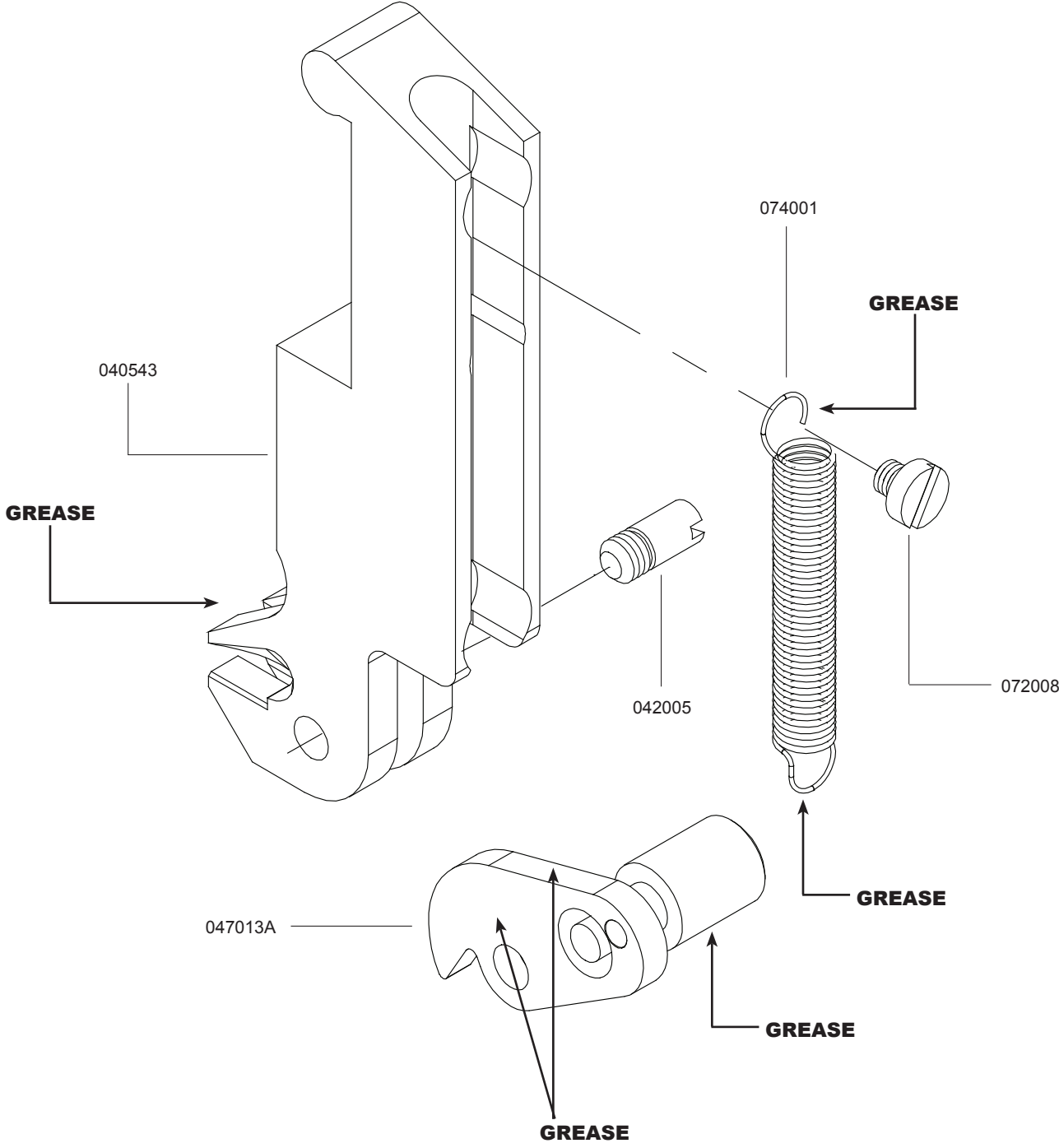

Wire Holder Assembly

DeLuxe PART No.	Replaces Muller No.	DESCRIPTION	QUANTITY
040543	0305.2033.3	Wire Holder	1
040543A	0305.2042.3	Wire Holder Assembly	1
042005	0305.2035.4	Hook Pivot Screw	1
047013A	0305.2050.4	Wire Holder Hook Assembly	1
072008	0030.3429	Screw	1
074001	0034.0102	Extension Spring	1

Clincher Plate Assembly

047016

Standard Clincher Plate
Complete Assembly

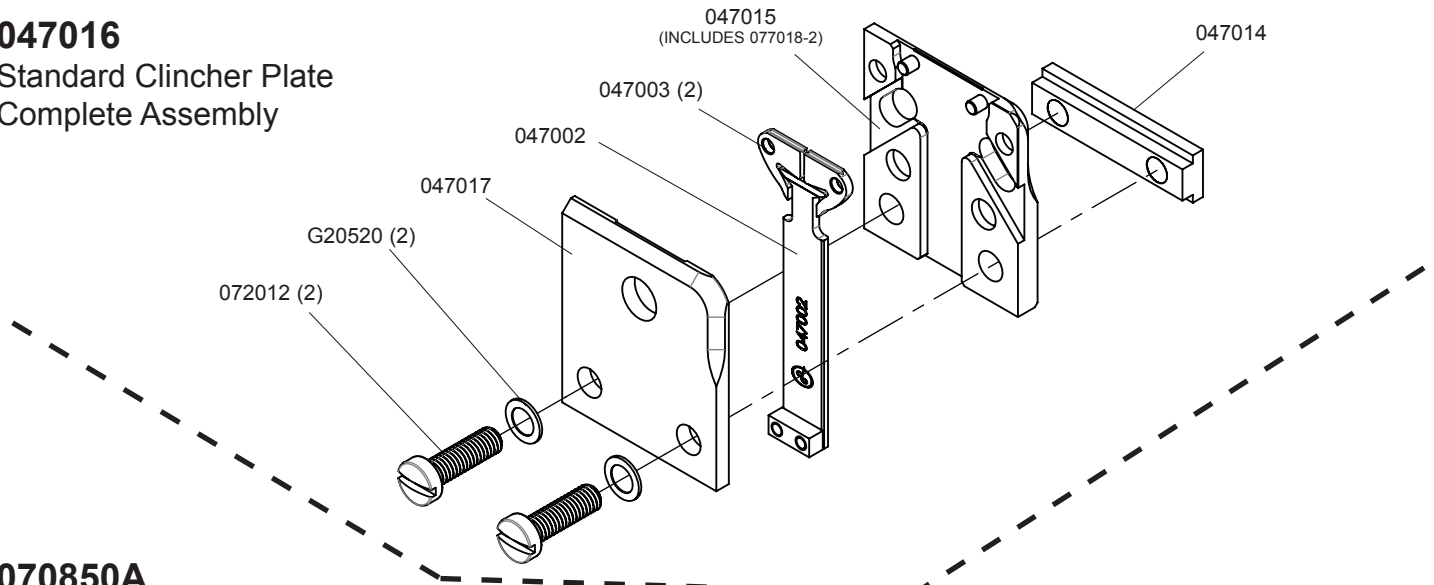

070850A

Medium Clincher Plate
Complete Assembly

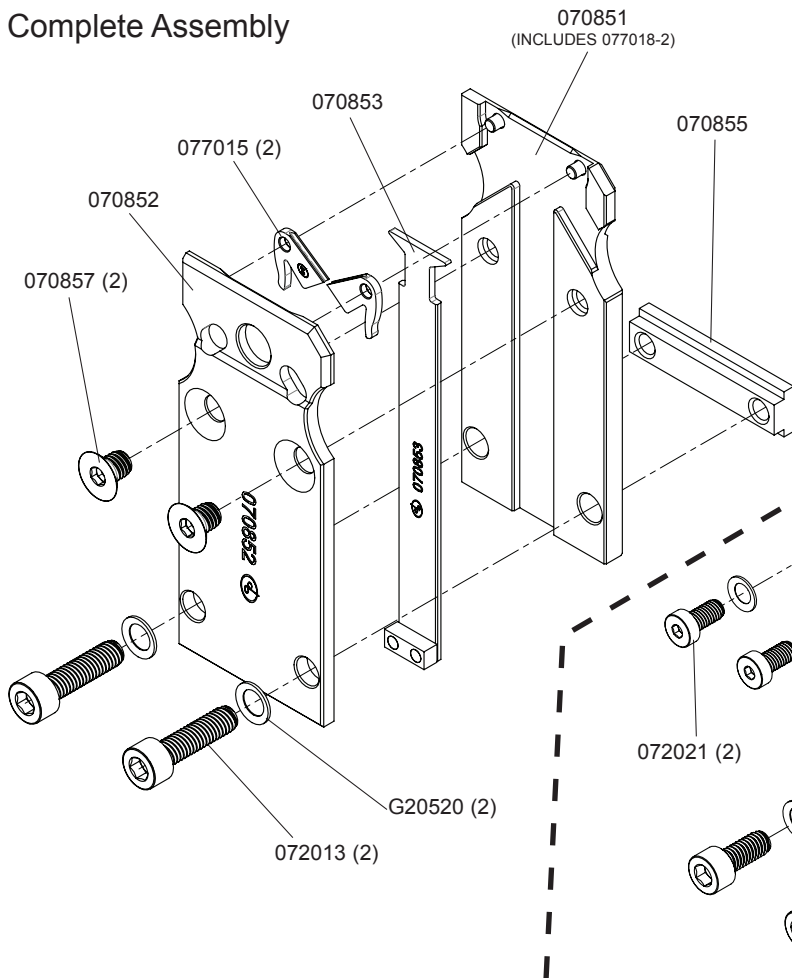

070830A

Long Clincher Plate
Complete Assembly

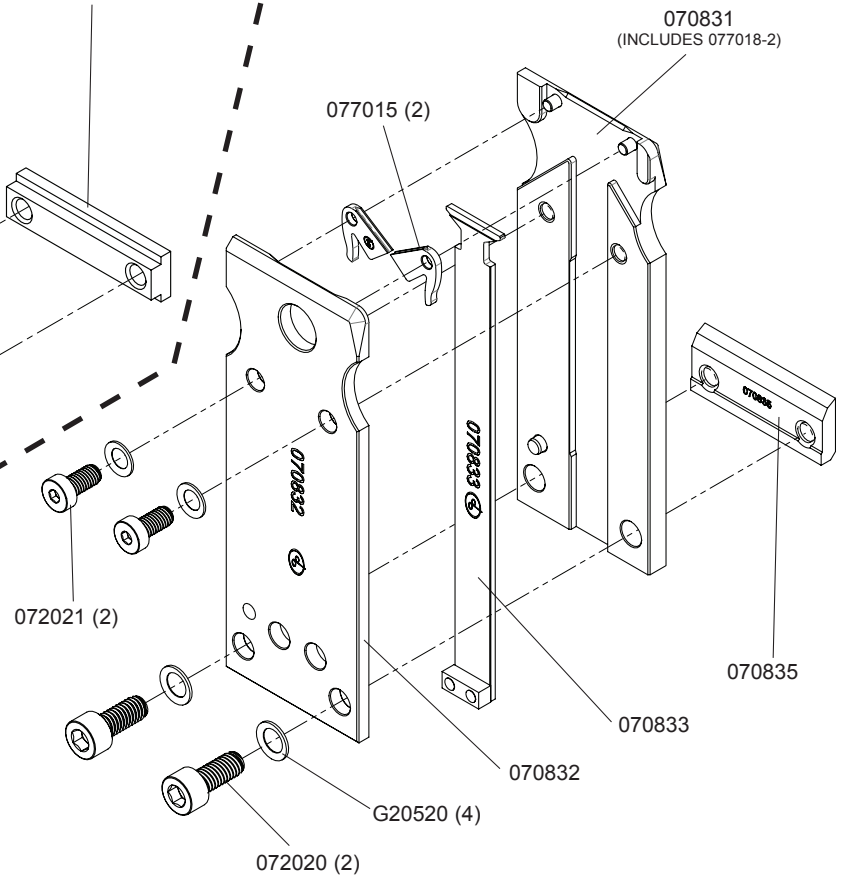

Clincher Plate Assembly

DeLuxe PART No.	Replaces Muller No.	DESCRIPTION	QUANTITY
G20520	0031.0557	Lock Washer Ribbed M6	2
047002	0249.1033.4	Clincher Slide Assembly 3/8	1
047003	0249.1050.3	Clincher Point 3/8	2
047014	0305.2053.4	Clincher Mounting Bar 3/8	1
047015	0305.2054.3	Clincher Back Plate Assembly 3/8	1
047016	0305.2054.3A	Clincher Plate Assembly Complete	1
047017	0305.2055.3	Clincher Front Plate 3/8	1
072012	0030.3488	Screw M6x1.0x20	2
077018-2	0881.0141.3-2	Clincher Pivot Point	2
070851		Rear Clincher Plate Assembly	1
070852		Front Clincher Plate	1
070853		Clincher Slide Assembly	1
070855		Clincher Mounting Bar	1
070857		Screw M6x1.0x8, FSHC	2
077015		Clincher Point	2
072013		Screw M6x1.0x22, SHCS	2
G20520	0031.0557	Lock Washer Ribbed M6	4
070831		Rear Clincher Plate Assembly	1
070832		Front Clincher Plate	1
070833		Clincher Slide Assembly w/carbide	1
070835		Clincher Mounting Bar	1
077015		Clincher Point	2
072020		Screw M6x1.0x14, SHCS	2
072021		Screw M5x0.8x10, Low Head SHCS	2
G20520	0031.0557	Lock Washer Ribbed M6	4

Part Number / Description Cross-Reference

040000	Bonnet	1	042007	Cutter Mounting Screw	1
040020	Fixed Cutter	1	043002	Grooved Pin	1
040110A	Large Feed Gear	1	043003	Pin	1
040111A	Feed Gear Pinion Assembly	1	044001	Centering Guide Spring, DB45	1
040114	Feed Gear Shaft	1	044002	Feed Cam Compression Spring	1
040118	Feed Release Cam Assembly	1	047001	Clutch Bearing, DB45	1
040119	Feed Release Handle	1	047002	Clincher Slide Assembly 3/8	1
040144	Lower Wire Tube	1	047003	Clincher Point 3/8	2
040145B	Moving Cutter - Steel	1	047004	Centering Guide, DB45	1
040152-25	Driver - .6MM	1	047005	Driver Slide Assembly, DB45	1
040162	Bender Slide Assembly	1	047006	Centering Guide Post, DB45	1
040183	Wire Holder Spring	1	047007B	Mounting Strap, DB45	1
040186	Friction Strip	1	047008	Feed Lever Assembly	1
040197BA	Cutter Box Assembly	1	047009	Teflon Bearing	2
040198	Cutter Operating Slide	1	047010	Limit Stop	1
040206BA	Wire Straightener Assembly	1	047011	Lower Wire Tube Holder	1
040210	Cutter Operating Spring	1	047012	Hook Guide	1
040230	Cutter Operating Lever	1	047013A	Wire Holder Hook Assembly	1
040231	Cutter Operating Lever Pivot Pin	1	047014	Clincher Mounting Bar 3/8	1
040244	Wire Tube Clamp	1	047015	Clincher Back Plate Assembly 3/8	1
040286	Wire Guide Spring Assembly	1	047016	Clincher Plate Assembly Complete	1
040543	Wire Holder	1	047017	Clincher Front Plate 3/8	1
040543A	Wire Holder Assembly	1	047018	Feed Cam Plunger Bushing	1
040548-25	Former RH 25-28 Wire	1	057002	Driver Slide Shaft	1
041001	Large Washer	1	070548L-25	Former LH 0.6 Wire	1
041002	Hex Head Jam Nut	1	070831	Rear Clincher Plate Assembly	1
042001	Screw M5x.8x8	2	070832	Front Clincher Plate	1
042002	Screw M5x.8x35	1	070833	Clincher Slide Assembly w/carbide	1
042003	Screw M5x.8x8	2	070835	Clincher Mounting Bar	1
042004	Screw M5x.8x10	1	070851	Rear Clincher Plate Assembly	1
042005	Hook Pivot Screw	1	070852	Front Clincher Plate	1
042006	Head Mounting Screw	1	070853	Clincher Slide Assembly	1

Part Number / Description Cross-Reference

070855	Clincher Mounting Bar	1	G20219	Disk Spring M4	4
070857	Screw M6x1.0x8, FSHC	2	G20273	Screw M4x.7x4, with Nylon Patch	1
070112	Small Feed Gear	1	G20287	Wire Oiler Felt Spring	1
070181	Upper Wire Tube	1	G20290	Flat Washer M5	1
070720	Wire Guide Tube	1	G20292	Wire Oil Felt Washer	2
070722	Tube Clamp	1	G20293	Wire Oiler Felt	2
071002	Shim Washer	1	G20297	Screw M6x1.0x40	1
071005	Lock Washer Ribbed M4	7	G20298	Nylock Lock Nut, M6x1	1
071006	Lock Washer Ribbed M5	3	G20312	Spirol Pin M3x12	1
072001	Screw M4x0.7x8	1	G20360	Hex Key Wrench 3.0mm	1
072003	Screw M4x0.7x12	2	G20361	Hex Key Wrench 2.5mm	1
072008	Screw M3x0.5x3	1	G20374	Hex Key Wrench 2.0mm	1
072010	Screw M4x0.7x5	1	G20520	Lock Washer Ribbed M6	2
072011	Screw M4x.7x12	3	G20589	Screw M4x.7x10	1
072012	Screw M6x1.0x20	2	G40402	Screw M5x0.8x16	1
072013	Screw M6x1.0x22	2	G50243	Spring Pin, M4 X 14	1
072015	Driver Retaining Screw	2	G50708	T-Handle Hex Key Wrench	1
072020	Screw M6x1.0x14	2	OSK127-1	Hook Guide Mounting Screw	1
072021	Screw M5x0.8x10, Low Head	2	OSK131M-MATL	Feed Gear Pinion	1
073001	E-Ring	1	OSK151M-2	Wire Straightener Knob	1
073002	E-Ring	1			
073003	Cotter Pin	1			
073006	Spring Pin M3x12	1			
073008	Rivet	1			
074001	Wire Holder Spring	1			
074002	Extension Spring	1			
077007	Set Collar	1			
077009	Feed Cam Plunger	1			
077012	Bender Slide Insert	1			
077015	Clincher Point	2			
077018-2	Clincher Pivot Point	2			
G20191	Screw M4x.7x8	2			
G20213	E-Ring, 1/8"	1			

LIMITED WARRANTY

DeLuxe Stitcher Company, Inc. warrants to the original retail purchaser that this product is free from defects in material and workmanship and agrees to repair or replace, at DeLuxe Stitcher's option, any defective product within 90 days from the date of purchase. This warranty is not transferable. It covers damage resulting only from defects in material or workmanship and does not cover conditions or malfunctions resulting from normal wear, neglect, abuse or accident.

This warranty is in lieu of all other express warranties. Any warranty of merchantability or fitness for a particular purpose is limited to the duration of this warranty. DeLuxe Stitcher shall not be liable for any incidental or consequential damages.

Some states do not allow limitations on how long an implied warranty lasts, or the exclusion or limitation of incidental or consequential damages, so the above limitations or exclusions may not apply to you. This warranty gives you specific legal rights and you may also have other rights which vary from state to state.

To obtain warranty service you must return the product, at your expense, together with proof of purchase to an authorized DeLuxe Stitcher Graphic Arts Dealer.

Always use genuine DeLuxe Stitcher parts. When ordering parts, please identify the part number, the part name, the wire size and crown size of your Stitcher.

DeLuxe Stitcher Company, Inc.
6635 West Irving Park Road
Chicago, Illinois 60634-2410
Phone: 773-777-6500 800-634-0810
Fax: 773-777-0156 800-417-9251
E-mail: info@deluxestitcher.com
Web Site: <http://www.deluxestitcher.com>

REGISTRATION

To better service your wire stitching needs, please take a moment to fill out and return this registration card.

CUSTOMER

Name : _____
(First) (Middle Initial) (Last)

Company : _____

Street Address : _____

City : _____ State/Province : _____ Zip : _____

Country : _____

Phone : _____ Fax : _____ E-mail : _____

PRODUCT

Machine(s) Purchased : _____

Serial Number(s) : _____

With Head(s) : _____
(Type/Quantity Purchased)

Serial Number(s) : _____

Head(s) Purchased : _____

Serial Number(s) : _____

DEALER

Date Received : _____

Dealer Name : _____

Dealer Street Address : _____

City : _____ State/Province : _____ Zip : _____

Country : _____

Dealer Phone : _____

Other Bindery Products Used : _____

Would you like information sent to you about new products that would benefit your company? Yes No

Please take a moment to fill out the attached card and mail it to DeLuxe Stitcher Company, Inc..
In addition, duplicate the information for your records to assist when making further inquiries.

PRODUCT

Machine(s) Purchased : _____

Serial Number(s) : _____

With Head(s) : _____
(Type/Quantity Purchased)

Serial Number(s) : _____

Head(s) Purchased : _____

Serial Number(s) : _____

DELUXE STITCHER GRAPHIC ARTS REPRESENTATIVE

Date Received : _____

Dealer Name : _____

Dealer Street Address : _____

City : _____ State/Province : _____ Zip : _____

Country : _____

Dealer Phone : _____

Common Replacement Parts for 3/8" Crown

Below is a list of the most common wear/replacement parts for the DB45 Stitcher Head. This guide should help you when ordering replacement parts. If the part you need is not listed below, please refer to the more detailed parts list on pages 43 - 44.

Description	Item Number
Fixed Cutter, DB45	040020
Moving Cutter - Steel	040145B
Driver - .6mm, DB45	040152-25
Wire Holder Spring	040183
Friction Strip, DB45	040186
Cutter Operating lever	040230
Screw, M5x0.8x8	042001
Hook Pivot Screw	042005
Head Mounting Screw	042006
Cutter Mounting Screw	042007
Hook Guide Mounting Screw	OSK127-1
Clincher Point 3/8"	047003
Mounting Strap	047007
Ribbed Lock Washer-M4	071005
Ribbed Lock Washer-M5	071006
Right Former, .6mm, DB45	040548-25
Screw, M4x0.7x12	042001
Driver Retaining Screw	072015
Rivet	073008
Extension Spring	074002
Bender Slide Insert	077012

PLACE
STAMP
HERE

**DELUXE STITCHER
COMPANY INC.**
6635 West Irving Park Road
Chicago, Illinois 60634-2410 U.S.A.
Attn: Customer Service

